

by

Donald G. Saari\*\*

Department of Mathematics  
Northwestern University

January 1989

Abstract

A discrete analog for a calculus argument about mapping between spaces is developed. This discrete "calculus argument" is used to characterize the "kinds of axioms" that lead to conclusions similar to that of Arrow's Theorem. In this manner, not only are new extensions of Arrow's theorem found, but this approach also is applied to economic allocation and welfare procedures. paradoxes from statistics and probability, the Hurwicz-Schmeidler result about pareto optimal Nash equilibria, the Gibbard-Satterthwaite theorem, Nakamura's Theorem about simple games, etc. Furthermore, a new, sharp class of possibility theorems are derived; they hold not only for transitive preferences, but for utility functions, probability measures, etc.

---

\*Original: October, 1987 (Title: Symmetry and Extensions of Arrow's Theorem) Revised: December, 1988.

\*\*This research was supported, in part, by NSF grants IRI8415348, IRI8803505, and a 1988-89 Fellowship from the Guggenheim Memorial Foundation.

Since Arrow's seminal work [1], social choice has become an active research area with lists of axioms forcing impossibility statements, conditions for possibility assertions, and the Gibbard [6] - Satterthwaite [20] theorem about manipulation. (See Sen [21] for a survey.) What is missing is a simple, unifying mathematical explanation - one that subsumes the various conclusions, that explains classical theorems and derives new ones, that directly extends social choice arguments to economics, statistics, and other areas, and that captures the elusive frontier between possibility and impossibility statements. Such a description is started here by shifting the emphasis from "particular sets of axioms" to the mathematical source of these results.

The unifying explanation is a discrete version of an elementary calculus argument. I illustrate the approach by relating Arrow's Theorem, several other social choice results, Nakamura's Theorem about simple games, a statistical paradox about contingency tables, the Hurwicz-Schmeidler study of optimal Nash equilibria, and certain questions about economic procedures. The axioms and assumptions from these areas have little to do with each other; what unifies them is that each is explained with the same discrete calculus argument. By characterizing the kinds of axioms amenable to this analysis, as I do here, results from different literatures are unified and extended in several directions.

The approach is a discrete version of an argument (Saari [19,18]), illustrated in the following example, that was developed to explain paradoxes associated with certain classes of social aggregation procedures.

**Example 1.** Consider the decision problem of selecting one of two urns containing red and blue balls. From the selected urn, a ball is chosen at random, and the player wins if it is red. If it is known that  $P(R|I) > P(R|II)$  (i.e., the probability of selecting a red ball is greater from urn I than from urn II), then the answer is obvious. With another set of urns where  $P(R|I) > P(R|II)$ , the same solution holds: from either set, select the first urn. Now, empty the two "good" urns I' and I'' into urn I, and "bad" urns II' and II'' into II. The solution for the new, aggregated problem need not be I; it could be II. For instance, if I' has 90 reds out of 240 balls, II' has 20 reds out of 90, I'' has 30 reds out of 60, and II'' has 110 reds out of 240, (this satisfies the first two inequalities), then  $P(R|I) < P(R|II)$  (urn I has 120 reds out of 300 while II has 130 reds out of 300).

To understand this behavior, known as *Simpson's paradox* (see [2,18,19] and their references), consider the mapping

1.1  $F = (F_1, F_2, F_3) = (P(R|I'), -P(R|II'), P(R|III'), -[P(R|I) - P(R|II)])$   
 from a space of probability distributions to  $R^3$ . The paradox occurs iff  $F$   
 meets either the positive or negative orthants of  $R^3$ ; i.e.,  $R^3_+$  or  $R^3_-$ . The  
 essence of the argument in [18,19] is that there is a probability distribution,  
 $q$ , where  $F(q) = 0$  and  $DF^q$ , the Jacobian of  $F$  at  $q$ , has rank three. Thus,  $F$   
 maps an open set about  $q$  to an open set,  $U$ , about  $0$ . As  $U$  meets all orthants  
 of  $R^3$ ,  $F$  meets  $R^3_+$  and  $R^3_-$ . So, Simpson's paradox follows because the  
 properties of the statistical procedure, as manifested by the rank conditions,  
 prohibit  $F$  from "squashing" the domain into  $R^3$  without the image overflowing  
 into  $R^3_+$  or  $R^3_-$ . ■

This simple calculus approach cannot be used if derivatives are not  
 defined, such as for discrete models as Arrow's Theorem or a model based on set  
 valued mappings, nor if the derivatives are complicated, such as for models  
 based on function spaces of utility functions. Nevertheless, with the  
 modifications developed here, the same theme holds. For a set  $S$ , I derive  
 conditions that ensure

$$1.2 \quad F = (F_1, F_2, F_3): S \rightarrow R^3$$

meets  $R^3_+$  or  $R^3_-$ ; i.e., conditions to force all  $F$  components to have the same  
 sign.

**Proposition 1.a.** For two components of  $F: S \rightarrow R^3$ , say  $F_i$ ,  $i = 1, 2$ , let each  
 component have a level set,  $L_i$ , with the following properties. i)  $F_i(L_i)$ ,  $i =$   
 $1, 2$ , have the same sign. ii)  $L_1 \cap L_2 \neq \emptyset$ . iii) There are level sets for  
 positive and negative values of  $F_3$  where each meets  $L_1 \cap L_2$ . The image of  $F$   
 meets either  $R^3_+$  or  $R^3_-$ .

b. Let a component of  $F: S \rightarrow R^3$ , say  $F_1$ , have a non-zero level set  $L_1$  with the  
 following property. There are level sets for positive and negative values of  
 $F_2$ , denoted by  $L_{2,+}$  and  $L_{2,-}$ , that intersect  $L_1$ . A positive and a negative  
 level set for  $F_3$  can be found such that each intersects both  $L_{1 \cap L_{2,+}}$  and  
 $L_{1 \cap L_{2,-}}$ . The image of  $F$  meets either  $R^3_+$  or  $R^3_-$ .

**Proof.** a. All points on  $L_1 \cap L_2$  fix the sign of  $F_1$  and  $F_2$ . The  
 assumption about the level sets of  $F_3$  means there is  $p \in L_1 \cap L_2$  where  $F_3(p)$  has  
 the same sign as  $F_1(p)$  and  $F_2(p)$ . ■

b. If  $F_1(L_1) > 0$ , then  $F_1$  and  $F_2$  have the same sign on  $L_1 \cap L_{2,+}$ . (Figure  
 depicts the geometric division of  $L_1$ .) By assumption,  $F_3$  positive and  
 negative level sets overlap  $L_1 \cap L_{2,+}$ , so part a applies. A similar argument  
 holds if  $F_1(L_1) < 0$ . ■

The calculus argument implicitly forces some of the level sets of the  $F_1$ 's to overlap as described in Proposition 1. (Use the implicit function theorem and the rank condition.) Indeed, this is why the conclusion of Example 1 follows. Thus, the essence of the calculus argument is captured by

Proposition 1. Conversely,  $L_1 \cap L_2 = \emptyset$  and  $L_1 \cap L_2 = \emptyset$ , so the value of  $F_2$  varies along  $L_1$ ; this defines the analog of  $\Delta F_2 \neq 0$ . The overlap conditions, which ensure that the analogs for  $\Delta F_2$  and  $\Delta F_3 \neq 0$  are independent, form the discrete analog of a rank condition for DF. As in Example 1, this "rank" condition forces the image of  $F$  to overflow into either  $R^+$  or  $R^-$ .

Proposition 1, the discrete version of the calculus argument, is used to analyze various paradoxes as well as to characterize the "kinds of axioms" leading to an Arrow type conclusion. (Throughout, informal remarks emphasize the close connection with calculus.)

In the remainder of this section, I illustrate Proposition 1 with two new results and one old one. In Section 2, I show why Proposition 1 explains the Nakamura and Arrow Theorems. In Section 3, I characterize a class of models that can be analyzed with Proposition 1 in the same way as Arrow's Theorem. I call this characterization the *overlap principle*. The flexibility of the overlap principle is illustrated by obtaining simple proofs of several known social choice results as well as to derive some new, and some whimsical ones. Thus, the connection among several well known social choice results along with problems from statistics, economics, and game theory becomes

immediate. (I emphasize known results to underscore the unifying effect of Theorem 2.) Moreover, because the overlap principle is based on the "level sets" of an arbitrary function (or correspondence, functional, etc.), extensions and new results are immediate. To illustrate how implicitly defined overlap conditions arise, a new proof of the Gibbard - Satterthwaite Theorem as well as the Hurwicz-Schmeidler theorem [11] about Pareto optimal Nash equilibria are given. The frontier between possibility and impossibility conclusions is described in Section 4; these results extend the nice results by Kalai and coauthors [13,14]. Section 5 contains the proofs.

### Contingency Tables in Statistics

Simpson's paradox describes a disturbing problem that can occur when contingency tables are collapsed to determine marginal information. It results from the combinatoric rules of conditional probabilities; e.g., the computation

2. This argument extends to  $F: S \rightarrow R^k, k \geq 2$ , where the goal is to find conditions so that  $F$  meets one of two diametrically opposite orthants of  $R^k$ . If necessary,  $(-1)$  multiplies of appropriate components of  $F$  make these orthants  $R^k_+$  and  $R^k_-$ .

of  $P(R11)$ ,  $(90/240) + (30/60) = (90+30)/(240+60)$ , disagrees with the rules of addition. Can a measure be invented to avoid Simpson's paradox? Namely, for the Example 1, is there a mapping  $G=(\mu, \mu, -\mu)$  from the space of probability distributions to  $R^3$  where  $G$  misses  $R^3$ , or  $R^3$ ? (See [8] for some measures and a related discussion.) To relate the new measures to probability, it is natural to require the signs of  $\mu$  and  $\mu$  to agree, respectively, with the signs of  $F_1$  and  $F_2$ . The measure  $\mu$ , which causes the paradox through the rules of computation, is accorded more flexibility. We require  $\mu$  to preserve at least one sign of  $F_3$ , but not necessarily the other. It follows from Proposition 1 that no such measures exist; Simpson's paradox is intrinsic to standard probability concepts.

To see this, let  $L_3$  be the set of all probability distributions where  $F_3(L_3)$  has the sign preserved by  $\mu$ . Thus,  $L_3$  is a portion of a level set for  $\text{sign}(\mu)$ . According to Example 1 and [19],  $F$  can achieve all combination of signs. But, different signs for  $F_1$  and  $F_2$  determine, respectively, different level sets for the  $\text{sign}(\mu)$  and  $\text{sign}(\mu)$ . Thus  $L_3$  is overlapped by these level sets in the manner described in Proposition 1, b. ■

**Compensation Test from Welfare Economics**

Proposition 1 formalizes a "natural approach" that has been used to prove certain assertions. To see this, consider the [24,p218] "compensation test [that] lies at the basis of much of applied welfare economics." Here, for  $n \geq 2$  goods, each of two agents is represented by a utility function from  $U^n = \{U: R^n \rightarrow R\}$  is smooth, all components of  $\Delta u$  are positive}. An allocation  $x = (x_1, x_2)$  is "better" than  $x'$ ,  $x >^B x'$ , if  $x$  has an reallocation,  $y = (y_1, y_2)$ ,  $y_1 + y_2 = x_1 + x_2$ , so that everyone is (Pareto) better off; e.g.,  $u_j(y_j) > u_j(x_j)$ ,  $j = 1, 2$ . Namely, the allocation is "better" if one agent can compensate the other to obtain a pareto superior outcome. To be useful, it must be that if  $x >^B x'$ , then  $x' >^B x$ . To test whether this is true for two allocations  $x'$  and  $x''$ , let  $F_1(u_1, u_2 | x', x'') = 1$  if  $x' >^B x''$ , otherwise let the value be  $-1$ . The component  $F_2$  emphasizes  $x''$ :  $F_2(u_1, u_2 | x', x'') = 1$  if  $x'' >^B x'$  and  $-1$  otherwise. If the compensation test is useful for the allocations  $x'$  and  $x''$ , it must be that  $F = (F_1, F_2): U^n \times U^n \rightarrow R^2$  never enters the positive quadrant of  $R^2$ . It does. For  $n = 2$  let  $x' = ((5, 2), (2, 5))$  and  $x'' = ((3, 3), (3, 3))$ . One reallocation of  $x'$  is  $((3.5, 3.5), (3.5, 3.5))$ ; each agent has more of each good than in  $x''$ . Thus for any  $u_j \in U^n$ , this reallocation is Pareto superior to  $x''$ . So, the positive level set of  $F_1, L_1^+$ , is the set of utility functions  $U^n \times U^n$ . To show that  $L_2^+$  meets  $L_1^+$ , it suffices to show there exist  $u_j \in U^n$  where the indifference set for  $u_1$  through  $(3, 3)$  passes above  $(5, 2)$  and the one for  $u_2$

that passes through  $(3,3)$  is above  $(2,5)$ . This is a standard construction. ■

### An Application to Economics

In economics, it is interesting to know whether "binary comparisons" can be used to describe more general conclusions. For instance, can aspects of a general solution concept for a trading model with three agents be recovered just by knowing what would happen in the binary trades among the pairs of agents? In models involving Marshallian demand and utility functions (e.g., the weak axiom of revealed preference, or consumer surplus), this issue is expressed in terms of "path dependency." I indicate next, with Proposition 1 and an example, why we should expect certain negative conclusions to be associated with models involving demand and utility functions.

Let an agent in a three commodity economy be characterized by her initial endowment,  $w = (w_1, w_2, w_3)$ , and  $u$ , her smooth, concave utility function. At a given price,  $p = (p_1, p_2, p_3)$ , the components of her excess demand function determine an ordinal ranking of the three commodities; i.e., the larger the excess demand for a commodity  $c_j$ , the more it is desired. If only two of the goods are traded, a binary relationship is defined. Namely, by holding a commodity fixed, say  $c_2 = w_2$ , and using the same prices  $(p_1, p_3)$ , a binary relationship is determined for the remaining two commodities  $\{c_1, c_3\}$  in terms of the excess demand. It is reasonable to expect that these binary rankings recapture her ranking of the three commodities at price  $p$ . They do not; the binary rankings need not be transitive. (So, Proposition 1 serves as a "single agent impossibility theorem.")

To prove this assertion via Proposition 1, let  $F_{i,j}(u; p, w) = 1$  if, when the third commodity is held fixed, the excess demand (based on  $u$ ,  $w$ , and  $(p_i, p_j)$ ) for  $c_i$  is greater than that for  $c_j$ ; if the excess demand for  $c_j$  is greater, then the value is  $-1$ . If  $F(u; p, w) = (F_{1,2}, F_{2,3}, F_{3,1}) = (1, 1, 1)$ , then the cycle  $c_1 > c_2, c_2 > c_3, c_3 > c_1$  occurs. Thus,  $F$  cannot enter  $R_3^+$  or  $R_3^-$ . It remains to show that the level sets of the components of  $F$ , which are sets of utility functions in a function space, overlap as described in Proposition 1.

Let  $w_i > 0, p_i > 0$  for  $i = 1, 2, 3$ . The plane in  $R^3$  parallel to the  $c_1, c_2$  plane passing through  $w$  represents all choices of demand for two commodities when the third is held fixed ( $c_3 = w_3$ ). In this plane consider the budget line passing through  $w$  with normal (price) vector  $(p_1, p_2)$ . Let  $L_{1,2,+} = \{u \mid$  the one dimensional budget line is tangent to an indifference set of  $u$  at a point where  $c_1 > w_1\}$ . (This restriction does not constrain the orientation of the indifference set in any other direction nor at any other point.) Because  $c_1 - w_1 > 0, c_2 - w_2 < 0, L_{1,2,+}$  is a "positive" level set for  $F_{1,2}$ ; it is a subset of

utility functions in a function space.

The positive level set for  $F_{2,3}, L_{2,3,+}$ , is defined in a similar

fashion. The one dimensional budget line determined by  $(p_2, p_3)$  is in the plane passing through  $w$  and parallel to the  $c_2, c_3$  plane.  $L_{2,3,+} = \{u \mid$  the budget

line is tangent to an indifference set of  $u$  at a point where  $c_2 > w_2\}$ . As this "local, point information" used to define  $L_{2,3,+}$  commits very little from the

utility function, a standard, geometric argument using different indifference sets of  $u$  proves that  $L_{1,2,+} \cap L_{2,3,+} \neq \emptyset$ ; i.e., sets of utility functions

satisfy both conditions. Finally, the level sets for  $F_{1,3}$  are determined by

the budget line associated with  $(p_1, p_3)$  in the plane passing through  $w$  parallel to the  $c_1, c_3$  plane. The indifference sets of the utility functions in

$L_{1,2,+} \cap L_{2,3,+}$  are restricted only by one-dimensional directions at two points on orthogonal planes. Thus, from the geometry, it is clear that some of these

utility functions have the one-dimensional,  $(p_1, p_3)$  budget line as a tangent direction (for some indifference set) at a point where  $c_1 > w_1$ , and others where

$c_3 > w_3$ . Thus,  $L_{1,2,+} \cap L_{2,3,+}$  is overlapped by both a negative and a positive level set of  $F_{1,3}$ . The assertion follows from Proposition 1a. ■

Marshallian demand is determined by *point information*. If the budget

restrictions are lower dimensional, as above, then the considerable flexibility left for the global properties of the utility function makes it easy to satisfy

the overlap conditions of Proposition 1. So, in any situation such as those illustrated in the last two examples, the defined, binary relations cannot be

expected to be transitive unless "global restriction" are imposed on the utility functions; e.g., they are homothetic [2]. (While details differ, a

similar argument explains certain "path dependency problems" in consumer surplus. I plan to discuss this in detail elsewhere.)

## 2. The Nakamura and Arrow Theorems

To illustrate Proposition 1 in a different setting and with  $N \geq 2$  agents,

I use Nakamura's Theorem. Let each agent have a complete, binary, (with no

indifference) transitive ranking of the candidates. The procedure to determine the rankings of any two candidates is in terms of a simple game. The game is

characterized by specifying the "winning coalitions"  $\Omega$ . Namely, if  $T$  is a

winning coalition ( $T \in \Omega$ ) and if all voters in  $T$  have the same ranking of the two candidates, then that is the group ranking. The conditions on  $\Omega$  are that i) if

$T \in \Omega$  and if  $T$  is a subset of  $T'$ , then  $T' \in \Omega$ , and ii) if  $T \in \Omega$ , then  $N \setminus T \notin \Omega$ .

An immediate example of a simple game is majority vote; here  $T$  is a winning

coalition iff  $|T| > n/2$ . Let  $\mathcal{J}$  represent a collection of winning coalitions with an empty intersection; i.e.,  $\mathcal{J} = \{T_j \mid T_j \in \Omega, \cap T_j = \emptyset\}$ . Nakamura's number,  $n(\Omega)$ , is  $\infty$  if no collection  $\mathcal{J}$  exists. If collections  $\mathcal{J}$  exist and if  $|\mathcal{J}|$  is the number of coalitions in  $\mathcal{J}$ , then  $n(\Omega) = \text{Min}_j \{|\mathcal{J}|\}$ . For example, if  $N \geq 3$  and  $\Omega$  represents majority vote, then  $n(\Omega) = 3$ .

**Proposition 2. (Nakamura)** The following are equivalent.

- i.  $n < n(\Omega)$ .
- ii. The binary rankings of  $C^n = \{c_1, \dots, c_n\}$  as determined by the simple game  $\Omega$  never are cyclic. Namely, if  $k \leq n$ , there is no profile where the outcomes define the rankings  $c_1 > c_2, c_2 > c_3, \dots, c_{k-1} > c_k$ , and  $c_k > c_1$ .

**Proof.** For each profile,  $p$ , define  $F_{1,j}(p) = 1$  if  $c_1 > c_j$ , and  $-1$  for the reversed inequality. Let  $F^k = (F_{1,2}, F_{2,3}, \dots, F_{k-1,k}, F_{k,1})$  be the mapping from the space of profiles to  $R^k$ . First I prove that if  $n \geq n(\Omega)$ , then cycles exist; i.e., I show for  $k = n(\Omega)$  that  $F^k$  meets the positive orthant of  $R^k$ . Let  $\mathcal{J}'$  be one of the above sets of winning coalitions where  $\mathcal{J}' = \{T_1, \dots, T_k\}$ . For  $j=1, \dots, k$ , the positive level set of  $F_{j,j+1}, T_{j,j+1}$ , includes all  $p$  where each voter in a coalition from  $\mathcal{J}'$  has the relative ranking  $c_j > c_{j+1}$ . Consider all profiles  $p$  where for  $j=1, \dots, k-1$  each voter in  $T_j$  has the relative ranking  $c_j > c_{j+1}$ . Clearly, such rankings are defined even if each voter is in several choices of  $T_j$ , so  $L_{1, \dots, k-1, +} = \cap_{j=1, \dots, k-1} L_{j, j+1} \neq \emptyset$ . If voter  $a \in T_k$ , then, by the definition of  $\mathcal{J}'$ , there is  $j$  so that  $a \notin T_j$ . Thus, at best,  $a$ 's relative rankings of  $\{c_1, \dots, c_j\}$ , and  $\{c_{j+1}, \dots, c_k\}$  are determined, but her relative ranking of  $\{c_1, c_k\}$  is free to be determined. If all  $a \in T_k$  have the ranking  $c_k > c_1$ , then  $p \in L_{k, 1, +}$ ; if they all have the reverse inequality, then  $p \in L_{k, 1, -}$ . Thus,  $L_{1, \dots, k-1, +}$  is overlapped by these two sets, so the conclusion follows from the obvious extension of Proposition 1a. ■

Suppose  $n < n(\Omega)$ ,  $k \leq n$ , and a cycle  $c_1 > c_2, c_2 > c_3, \dots, c_{k-1} > c_k, c_k > c_1$  is defined where  $T_j$  is the winning coalition for the ranking of  $\{c_j, c_{j+1}\}$ ; let  $L_{1, \dots, k-1, +}$  be as defined above. The assertion means that  $L_{1, \dots, k-1, +}$  must meet  $L_{k, 1, +}$ . But, according to the definition of the Nakamura number, there are choices of  $a \in T_k$  that are in all other choices of  $T_j$ . Thus,  $a$ 's ranking of the  $k$  candidates is uniquely determined. In particular,  $a$  has the ranking  $c_1 > c_k$ , which contradicts the fact  $a \in T_k$ . ■

Nakamura's number can be viewed as determining a lower bound on the rank for  $DF^k$ . As demonstrated in the proof, the increased rank is achieved through a coordination of agents' actions. The proof of Arrow's Theorem via



Proposition 1 is achieved in a related manner; the actions of the agents are coordinated to satisfy the overlap property. Another new feature appears in Arrow's Theorem; the relevant choice of a function, denoted by  $F^i$ , is implicitly defined by the axioms. To keep the exposition simple, I discuss a two voter, three candidate social welfare process. But first a geometric representation for the complete, binary, transitive rankings of the candidates  $\{c_1, c_2, c_3\}$  is given.

In an equilateral triangle identify each vertex with a candidate and define a binary relationship of a point in terms of its proximity to a vertex. Thus, point  $p$  corresponds to the ranking  $c_1 > c_2$  iff  $p$  is closer to vertex  $c_1$  than to vertex  $c_2$ . This relationship divides the equilateral triangle, as in Figure 2, where the open regions - the smallest triangles - correspond to strict rankings without "indifference" among the candidates, while the line segments and the barycentric point correspond to rankings with indifference. For instance, region A corresponds to the ranking  $c_1 > c_2 > c_3$ , while the line segment between regions C and D represents  $c_3 > c_1 = c_2$ . Let  $P(1,2,3)$  denote the 3' open regions where the rankings do not admit indifference. Let  $P(i,j)$  denote the two equivalence classes of rankings in  $P(1,2,3)$  where  $c_i > c_j$  and where  $c_j > c_i$ ; e.g.,  $P(1,2) = \{c_1 > c_2\} = \{A,B,C\}$ ,  $\{c_2 > c_1\} = \{D,E,F\}$ . Geometrically, the sets in  $P(i,j)$  are the two right triangles separated by the indifference line  $c_i = c_j$ . I show that Arrow's Theorem is a consequence of how these right triangles overlap one another.

In a two voter, three candidate context without indifference, a social welfare function is a mapping

$$2.1 \quad F: P(1,2,3) \times P(1,2,3) \rightarrow P(1,2,3).$$

The cartesian product represents the two voters' possible rankings, so Eq. 2.1 contains the usual *universality of domain* requirement. Arrow's conditions are replaced with the following weaker requirements.

1. Independence of irrelevant alternatives, IIA, requires for each  $(i,j)$  that the relative ranking of  $\{c_i, c_j\}$  depends only on the voters' relative rankings of these candidates. This is equivalent to requiring for each  $(i,j)$ , that

$$2.2 \quad F: P(i,j) \times P(i,j) \rightarrow P(i,j).$$

In other words, the  $P(i,j)$  ranking of  $F$  is uniquely determined by the  $P(i,j)$  rankings of the two agents; the relative ranking of  $c_k$  has no influence on the  $P(i,j)$  outcome.

2. "Unanimity" forces  $F$  to be onto; all six rankings of  $P(1,2,3)$  are in the image of  $F$ . I use the weaker condition that for at least two pairs

(i,j), F, in Eq. 2.2, is onto. (This is satisfied if Image F = {c<sub>1</sub>>c<sub>2</sub>>c<sub>3</sub>, c<sub>3</sub>>c<sub>2</sub>>c<sub>1</sub>}).

3. If the first voter is a dictator for F, then F can be represented by a mapping depending only on the first variable. I require that F cannot be represented by a function of a single variable.

Theorem 1. There does not exist a mapping given by Equation 2.1 that satisfies conditions 1, 2, and 3. If F, given by Eq. 2.1, satisfies 1 and 2, then it can be represented by a function of a single variable generated either by mapping each relationship c<sub>1</sub>>c<sub>2</sub> to itself (a dictator), or by mapping each relationship c<sub>1</sub>>c<sub>2</sub> to c<sub>2</sub>>c<sub>1</sub> (an anti-dictator).

Arrow's theorem is an immediate consequence of Theorem 1. An earlier version of Theorem 1 (for N≥2 voters and n≥3 candidates) is in Saari [17]; also see Kim and Rouch [15] and Wilson [25]. I prove this stronger version of Arrow's Theorem with Proposition 1.

**Proof.** If F exists, IIA can be used to define the mappings F<sub>1,j</sub>: P(i,j) × P(i,j) → {-1, 1} in the following manner. Identify c<sub>1</sub>>c<sub>2</sub> with 1 and c<sub>2</sub>>c<sub>1</sub> with -1; in this way, each P(i,j) ranking of F is identified with either -1 or 1. According to Eq. 2.2, this value depends only on the P(i,j) ranking of each voter. This defines F<sub>1,j</sub>. Associated with F is the induced mapping F<sub>1 = (F<sub>1,2</sub>, F<sub>2,3</sub>, F<sub>3,1</sub>) : P(i,j) × P(i,j) → {-1, 1}^3. If F exists, F<sub>1</sub> must miss (1,1,1) (the cycle c<sub>1</sub>>c<sub>2</sub>, c<sub>2</sub>>c<sub>3</sub>, c<sub>3</sub>>c<sub>1</sub>) and (-1,-1,-1); i.e., F<sub>1</sub> must miss R<sub>3<sup>+</sup></sub> and R<sub>3<sup>-</sup></sub>.</sub>

As I show, the level sets of the components of F<sub>1</sub> overlap in the manner described in Proposition 1, so F<sub>1</sub> must meet one of the two orthants. (The level sets for F<sub>1,j</sub> are in P(i,j) × P(i,j).) To do this, assume there are situations where when voter 2 has a specified relative ranking of {c<sub>1</sub>, c<sub>2</sub>}, voter 1 can change the F<sub>1,2</sub> value by changing her relative rankings of the pair, and when voter 1 has a specified relative ranking of {c<sub>2</sub>, c<sub>3</sub>}, voter 2 can change the F<sub>2,3</sub> value by varying his P(2,3) ranking. (This assumption is verified below.) Using Figure 2, voter 1 varies her rankings either between {A,F} or between {C,D}, and voter 2 varies his rankings either between {A,B} or between {D,E}. The exact choice is determined in this way: If voter 2 needs the relative ranking c<sub>2</sub>>c<sub>1</sub> so that voter 1 can alter the F<sub>1,2</sub> value, then voter 2 varies between {D,E}. Otherwise (e.g., either voter 1 always determines the F<sub>1,2</sub> image, or does so only if voter 2 has the relative ranking c<sub>1</sub>>c<sub>2</sub>) let voter 2 vary between {A,B}. In this manner, the preferences of voter 2 are in a fixed

$P(1,3)$  class (on the same side of the indifference line  $c_1=c_2$ ), in the vary between  $P(2,3)$  classes. The choice for voter 1 between  $\{A,F\}$  or  $\{C,D\}$  is selected in the same coordinated manner. Each choice is in a different  $P(1,2)$  class, so choose the one required of voter 1 to allow voter 2 to change the  $F_{2,3}$  values. With this choice, voter 1 is in a fixed  $P(1,3)$  class, a fixed  $P(2,3)$  class, but can vary between  $P(1,2)$  classes.

With these choices, neither voter changes  $P(1,3)$  classes, so  $F_{3,1}$  has a fixed value of either 1 or -1. On the other hand, each voter can vary the sign of one component of  $F^i$  while satisfying the specified condition needed to allow the other agent to vary the sign of the last component. Thus, we have the contradiction that there are situations where all three components of  $F^i$  have the same sign. This proves that  $F$  does not exist. (This argument proves that the level sets of the components of  $F^i$  overlap as described in Proposition 1b.) It remains to verify the assumption that if  $F$  exists, there are two different pairs of candidates where each voter affects the rankings of one of them. *Claim. There are profiles where the image of  $F$  changes when only one voter changes preferences.* To show this, let  $x_1$  and  $x_2$  be profiles with different  $F$  images. Consider the two step path going from  $x_1$  to  $x_2$ , where, at the  $i$ th step, the  $i$ th voter's rankings change,  $i = 1, 2$ . At one of these steps, the image of  $F$  must change, so the claim follows. More is possible;  $F$  cannot be represented as a function of a single variable, so there are profiles where, when only  $i$ th agent changes rankings, the image of  $F$  changes,  $i = 1, 2$ .

If the image of  $F$  changes, so does the relative ranking of a pair of candidates. Thus, by IIA, each situation described above corresponds to a setting where the following is true. If one agent has a specified relative ranking of a particular pair of the candidates while the other agent varies the relative rankings of this pair, then the relative  $F$  ranking of this pair changes. It remains to show that each voter can affect the outcome of a different pair of candidates. If not, then each voter affects the relative rankings only of, say,  $\{c_1, c_2\}$ ; i.e., the value of  $F_{1,2}$ . By (2), for at least one other pair  $(i,j)$ , say  $(2,3)$ ,  $F$  has different  $P(2,3)$  images. Using the argument of two preceding paragraphs, it follows that there are profiles where when only one voter changes  $P(2,3)$  rankings, the  $P(2,3)$  image of  $F$  changes; i.e., the value of  $F_{2,3}$  changes. By a relabelling of the indices, if necessary, the assertion is proved. ■

The second part of the theorem also is based on the discrete calculus argument given by Proposition 1. Obviously, a dictator or an anti-dictator can

be defined, so it remains to show that there are no other choices for a mapping of a single voter. One possibility is that a component, say  $F_{1,2}$ , is constant valued; i.e.,  $P(1,2,3)$  is a level set for  $F_{1,2}$ . By (2), the other components of  $F^i$  are not constant valued; their level sets are the two classes (right triangles) of  $P(i,j)$ . It now follows from Figure 2 that the level set of  $F_{1,2}$  is overlapped in the manner described in Proposition 1b. Thus, such a mapping does not exist. The remaining possibility is for  $F$  to have the voter's relative binary ranking of one pair reversed while the relative binary ranking of another pair is preserved. So, without loss of generality, assume  $F: P(1,2,3) \rightarrow P(1,2,3)$  satisfies (1) and (2),  $F$  preserves the  $P(1,2)$  ranking, but reverses the  $P(2,3)$  ranking. Thus the image of  $F^i$  restricted to  $P(c_1 > c_2) \cap P(c_3 > c_2) = \{B, C\}$  is  $\{1, 1, \pm 1\}$ . (Because  $F$  preserves the  $P(1,2)$  ranking,  $F_{1,2}(c_1 > c_2) = 1$ ; because  $F$  reverses the  $P(2,3)$  ranking,  $F_{2,3}(c_3 > c_2) = 1$ . This means  $\{B, C\}$  is in  $L_{1,2,+} \cup L_{2,3,+}$ . But,  $B$  and  $C$  are in different  $P(1,3)$  classes, and, by (2), in different level sets of  $F_{3,1}$ . Thus  $\{B, C\}$  is overlapped by the level sets of  $F_{3,1}$  in the manner described in Proposition 1a. ■

Both parts of the proof use the fact that the induced mapping,  $F^i$ , must miss  $R_3^+$  and  $R_3^-$ . The second part proves that even if  $F$  exists, Proposition 1 imposes restrictions on how  $F^i$  and  $F$  are defined. This should be expected; the discrete analog of  $\Delta F_{i,j}$  must be suitably restricted so that  $F^i$  misses  $R_3^+$  and  $R_3^-$ . But, a restriction on  $\Delta F_{i,j}$  imposes a restriction on  $F^i$  and  $F$ . This theme continues throughout; particularly in Section 4 where domain restrictions leading to possibility theorems impose restrictions on the  $\Delta F_{i,j}$ 's. For the first part of the theorem,  $N \geq 2$  agents are required because, with a single agent, the level sets for  $F_{i,j}$  (i.e., the two  $P(i,j)$  sets) do not overlap as described in Proposition 1 -  $DF^i$  has rank 1. More agents create new variables for the domain. So to create the overlap, the coordinated actions of each agent determines the "overlap" of a different component of  $F^i$ . In the "calculus argument", each row of  $DF^i$  becomes  $\Delta F_{i,j} = (\Delta^1 F_{i,j}, \dots, \Delta^N F_{i,j})$  where  $\Delta^k F_{i,j}$  is voter  $k$ 's gradient. Thus, to increase the rank of  $DF^i$ , the extra components, the  $\Delta F_{i,j}$ 's defined by other agents, are needed.<sup>3</sup> Also,

Proposition 1 only uses the geometric manner in which the level sets overlap. So, as suggested by the examples in Section 1, one must expect the conclusions of Theorem 1 to extend to wide classes of models. This is the theme of Section 3.

3. This argument provides a "calculus" intuition for the insightful Blau (see

### 3. The Overlap Principle

Some interesting consequences of Proposition 1 arise in axiomatic models with  $N \geq 2$  agents. Here, axioms, such as IIA, define the induced mapping  $F_1$ . As in Section 2, the level sets overlap through a coordination of the actions of several agents. But, this is true only if each agent's contribution to the level sets of the components of  $F_1$  satisfy appropriate properties. Arrow's Theorem gives one set of properties; a more inclusive set is in Theorem 2. I illustrate Theorem 2 with examples selected to emphasize that the same argument subsumes many of the classical theorems.

Notation: Let  $|A|$  denote the cardinality of set  $A$ . If  $A = \{A_1, \dots, A_n\}$  and  $B = \{B_1, \dots, B_m\}$  are collection of sets, let  $A \cap B = \{A_j \cap B_k : 1 \leq j \leq n, 1 \leq k \leq m\}$ .

Let  $D = D_1 \times \dots \times D_N$  be the cartesian product of the  $N \geq 2$  sets  $D_k$ ; let  $R$  be a given set, and let

$$3.1 \quad F: D \rightarrow R$$

be given. So,  $D$ , a product set, replaces the set  $S$  in Proposition 1. Just as there are no restrictions on the choice of  $S$ , there are no restrictions on the choice of  $D_j$  -- it could be the  $j$ 'th agent's set of binary transitive rankings, probability measures, spaces of admissible strategies, function spaces of

utility functions, or anything else. The choice of  $D_j$  can differ from agent to agent where, say,  $D_1$  is a set of transitive rankings,  $D_2$  is a set of

probability measures, etc. The critical aspect is not the kind of information represented by  $D_j$ , but how the information for each agent is divided into

"level sets."

In Theorem 1,  $D_j = P(1, 2, 3)$ ,  $j = 1, \dots, N$ . The primitive -- the IIA axiom

-- divides  $P(1, 2, 3)$  into the three pairs of independence sets  $P(i, j)$ . I take

the opposite approach; my primitive is the division of each  $D_j$  into

*independence sets*. In this manner, the division defines a "class of axioms;"

any axiom or assumption that admits this division of  $D_j$  is in this "class of

[10] -- Fishburn [5] theorem asserting that Arrow's impossibility conclusion need not hold with an infinite number of voters. Here,  $\Delta F_{i,j}$  has an infinite number of  $\Delta F_{i,j}$  components where  $F_{i,j}(p+v) - F_{i,j}(p) \approx (\Delta F_{i,j}(v))$ . For finite  $N \geq 1$ , the inner product is the vector dot product. Thus, if  $\Delta F_{i,j}^k \neq 0$ , a change for voter  $k$  can affect the value of  $F_{i,j}$ . But with an infinite number of voters, there are many inner products (e.g., the Lebesgue integral) where if  $v$  represents changes of a finite number of voters (i.e.,  $v$  changes only at a finite number of points), the value of  $F_{i,j}$  remains fixed. With some additional minor modifications of the kind suggested by Proposition 1, the possibility assertion follows. Fishburn's [5] and Hansson's [10] proofs reflect the spirit of this argument.

axioms." Therefore, the key element is the characterization of independence, or *informational equivalence classes*,  $I_j(k) = \{I_j(k,1), I_j(k,2)\}$ , for each  $D_k$ . (Superscript  $j$  indices the three "independence conditions",  $k$  identifies the agent, and the remaining index distinguishes the two classes.) Just as in the Nakamura and Arrow Theorems where each voters actions contribute one point to the level sets of each  $F_j$ , it helps to think of these two  $I_j(k)$  sets as the two "points" agent  $k$  contributes to the two level sets of  $F_j$ . Let  $I_j$  be the cartesian product  $X^{k=1, \dots, N} I_j(k)$ .

Once the independence classes are defined, the approach of Section 2 is used. Namely, the independence classes define components of an appropriately defined induced mapping  $F^I$  from  $D$  into  $R^3$ ; i.e., the level sets for  $F_j$  are in  $I_j$ . To complete the program, conditions on each agent's informational classes (e.g., conditions on the kinds of axioms applied to each agent) are needed to ensure that the calculus argument, as captured by Proposition 1, applies.

**Definition.** The independence sets satisfy the *domain overlap* condition if for each choice of  $k$  and for each permutation  $(a,b,c)$  of  $(1,2,3)$ , there is a permutation  $(u,v)$  of  $(1,2)$  so that each of

$$3.1 \quad I_a(k,1) \cap I_b(k,u) \text{ and } I_a(k,2) \cap I_b(k,v) \text{ meet both } I_c(k,1) \text{ and } I_c(k,2).$$

Moreover, there is at least one  $k$  that satisfies the *restricted domain condition* where, for each permutation  $(a,b,c)$ , Eq. 3.1 is satisfied for a

unique permutation  $(u,v)$ . (Thus,  $I_a(k,1) \cap I_b(k,u)$  does not meet both  $I_c$  classes for both choices of  $u$ .)

It is easy to show (with Figure 2) that if  $D_k = P(1,2,3)$  and  $I_{i,j}(k) = P(i,j)$ , then each agent satisfies the restricted domain condition; the domain overlap conditions include and extend the binary transitive rankings. (The overlap conditions admit many situations other than these rankings.) The restricted domain condition is imposed to exclude statements where, with even one agent, Proposition 1 serves directly. To see this, suppose  $k$  is the only agent. The level sets for  $F_j$  are  $I_j(k,u)$ ,  $u = 1,2$ , where each level set is identified with a different sign of  $F_j$ . The unique permutation in the "restricted domain" version of Eq. 3.1 requires  $I_a(k,1)$  and  $I_b(k,u)$  to be associated with different signs of the respective components of  $F^I$ . (If not, then the overlap conditions on  $I_c(k)$ , the level sets for  $F_c$ , satisfy Proposition 1a.) Similarly,  $(I_a(k,2), I_b(k,v))$  have opposite signs. If no agent satisfies the restricted domain condition, Proposition 1 applies directly.

The range,  $R$ , is any set. The critical aspect is its division into independence sets given by  $R_j = \{R_j^1, R_j^2, \dots, R_j^k\}$ ,  $k \geq 2$ ,  $j=1, 2, 3$ . The sets,  $R_j^k$ , replace the division of the range  $P(1, 2, 3)$  into the three  $P(1, j)$  classes of two sets. I allow for more than two outcomes to admit models that include "indifference" between alternatives, etc. Again, following the lead of Section 2, the conditions imposed on the  $R_j$  sets are to prohibit  $F^i$  from entering  $R_j^k$  or  $R_j^l$ . These *range overlap conditions* specify how "pairs" of the range sets should overlap one another. So, whenever these conditions occur -- whether the range space consist of Walrasian allocations, game theoretic outcomes, lotteries, utility functions, or binary, transitive rankings -- an argument involving Proposition 1 applies. Thus, the following set theoretic conditions form a straight-forward procedure to determine whether a particular model admits the appropriate restrictions on the induced map  $F^i$ .

**Definition.**  $\{R_j\}_{j=1, 2, 3}$  satisfies the *range overlap* condition if whenever  $R_j^a$  denotes some pair of subsets of  $R_j$ , then for each permutation  $(a, b, c)$  of  $(1, 2, 3)$  and for each pair of subsets, there are two subsets in  $R^a \cap R^b$  that do not meet the same subset of  $R_c$ .

**Example 2.** If  $R_j^k = P(j, k)$ , then  $R_1, 2 \cap R_2, 3 = P(1, 2) \cap P(2, 3) = \{c_1 > c_2 > c_3\}$ ,  $\{c_3 > c_2 > c_1\}$ ,  $\{c_2 > c_1 > c_3\}$ ,  $\{c_1 > c_3 > c_2\}$ . The two singleton sets have different  $\{c_1, c_3\}$  rankings, so they are in different  $R_1, 3 = P(1, 3)$  classes.

**Definition.** The triple  $\{F, \{I_j\}, \{R_j\}\}$ ,  $j=1, 2, 3$ , satisfies the *binary overlap principle* if:

1. For each  $j$  and each  $k = 1, \dots, N$ , the two subsets  $\{I_j^k(1), I_j^k(2)\}$  are either disjoint or equal. For each  $j$ , there is at least one agent where these sets are disjoint. For all  $k$ , the sets  $\{I_j^k(k)\}$  satisfy the domain overlap condition.

2. a. The  $\{R_j\}$  sets satisfy the range overlap condition.  
 b. For  $j = 1, 2, 3$ ,  $F: I_j \rightarrow R_j$ .  
 c. For at least two choices of  $j$ ,  $F$  meets at least two of the  $R_j$  sets.

For models with interpersonal comparisons, the relationships among the agents' rankings define a subset,  $E$ , of  $D$ . The special case considered here is where the relative ranking of one agent,  $a$ , determines the relative rankings of other agents. Let  $A$  be a subset of  $\{1, \dots, N\}$  and let  $E_j(a, A)$  specify a  $I_j^k(k)$

class,  $k \in A$ , in terms of a specified  $I_j(a)$  class. For instance,

$$E_{1,2}(\{1, \dots, N\}) = \{(c_1 > c_2)^N, (c_2 > c_1)^N\}$$

relative ranking of  $\{c_1, c_2\}$  as agent 1. (This set models the Pareto condition

in Corollary 2.6.)

As in Section 2, the "dictator" is replaced with the more general

concept of a function of a single variable.

**Definition.** Let  $\pi_k: D \rightarrow D_k$  be the natural projection mapping. The mapping

$F: D \rightarrow R$  is represented by a function of a single variable if there exists  $k$

and a  $g_k: D_k \rightarrow R$  so that  $F = g_k(\pi_k)$ .

The overlap conditions capture the essence of the geometry used to

prove Theorem 1. Thus, Theorem 2 should be expected. (The proof is in Section

5.)

**Theorem 2.** Let  $F: D \rightarrow R$  satisfy the binary overlap principle with the sets

$\{I_j\}$  and  $\{R_j\}$ . When  $F$  is viewed as a mapping

$$3.2 \quad F: \prod_j I_j \rightarrow \prod_j R_j,$$

there is an index  $k$  so that  $F$  is represented by a function of a single

variable,  $g_k$ . If an interpersonal restriction  $E^s(a, A)$  is imposed for some  $s$  and

$a$ , then either the same conclusion holds, or  $F$  does not exist.

Let  $F$  meet the pairs  $\{R_j^1, R_j^2\}$ ,  $j=1, 2, 3$ . There are precisely two ways to define  $g_k$

where each requires  $F: I_j \rightarrow R_j$  to be nonconstant. The mapping is uniquely

determined by whether  $I_j(k, 1)$  or  $I_j(k, 2)$  is mapped to  $R_j^1$ . Voter  $k$  satisfies

the restricted domain condition, and all three  $I_j(k)$  classes have two disjoint

elements. If no such  $k$  exists,  $F$  does not exist.

As Theorem 2 is based on how level sets overlap, it permits Arrow's

theorem to extend to a wide class of new models. Moreover, new features

emerge. The first is that each agent can have a different kind of independence

sets. The second is the last sentence; if no agent satisfies the restricted

domain condition, then  $F$  does not exist even with a single voter. Here the

theorem reduces to Proposition 1; a single agent version of Arrow's Theorem.

### Applications of Theorem 2

To demonstrate Theorem 2, I start by showing how standard results from

social choice are immediate consequences. For  $C^n = \{c_1, \dots, c_n\}$ , let  $P(1, \dots, n)$

denote the set of all  $n!$  complete, binary transitive rankings without ties of

these candidates. If  $A$  is a subset of  $C^n$ , then an element of  $P(A)$  is the set



of  $n!/|A|$  rankings of  $P(1, \dots, n)$  that preserve the relative ranking of the candidates in  $A$ . So  $P(A)$ , the obvious extension of  $P(i, j)$ , consists of  $|A|!$  disjoint subsets of  $P(1, \dots, n)$ . The first corollary extends Theorem 1 to any (finite) number of candidates and voters.

**Corollary 2.1.** Let  $n \geq 3$ ,  $N \geq 2$ , and  $F: (P(1, \dots, n))^N \rightarrow P(1, j)$ . If for each  $(i, j)$ ,  $F$  satisfies the independence condition  $F: (P(i, j))^N \rightarrow P(i, j)$  where the mapping is onto, then  $F$  is represented by a function of a single variable that corresponds to either a dictator, or an anti-dictator.

**Proof.** Let  $I_1(k) = P(1, 2)$ ,  $I_2(k) = P(2, 3)$ , and  $I_3(k) = P(3, 4)$ . The overlap conditions are satisfied, so  $F$  is represented by a function of one variable on the domain  $P(1, 2)^N \times P(2, 3)^N \times P(3, 4)^N$ . Next, let

$I_1(k) = P(1, 2)$ ,  $I_2(k) = P(2, 4)$  and  $I_3(k) = P(1, 4)$ . It follows from Theorem 2 that  $F$  can be represented by a function of a single variable over  $P(1, 2)^N \times P(2, 4)^N \times P(1, 4)^N$ . Both of these domains include  $P(1, 2)^N$ , so in both cases the same voter is the dictator (or the anti-dictator). The proof is completed with the obvious induction argument. ■

The distinction between whether a dictator or an anti-dictator reigns can be determined with a monotonicity condition, such as a pareto condition on some pair, or even by specifying the image of a single point.

**Corollary 2.2. a.** Suppose in addition to the assumptions in Corollary 2.1, it is known that  $F((c_1 > c_2 > \dots > c_n)^N)$  is in the  $P(1, n)$  class corresponding to  $c_1 > c_n$ . Then  $F$  is represented by a dictator.

b. Let  $p$  be a profile in  $P(1, \dots, n)^N$ . If the assumptions of Corollary 2.1 are satisfied and  $F$  is represented by  $g_k$ , then, for any  $(i, j)$ , the  $P(i, j)$  image of  $F(p)$  determines whether  $k$  is a dictator or an anti-dictator.

These corollaries generalize the various extensions of Arrow's theorem.

(For instance, no monotonicity is involved, and we only need that  $F: P(i, j)^N \rightarrow P(i, j)$  is onto for two pairs from each triplet of candidates.) Corollary 2.3 introduces the votes. For this statement, let  $P^*(1, \dots, n)$  be the set of all complete, transitive, binary rankings of the  $n$  alternatives, even those with ties. If  $A$  is a subset of  $\{1, \dots, n\}$ , then an element of  $P^*(A)$  consists of all of the rankings in  $P^*(1, \dots, n)$  with the same relative ranking -

including possible tie votes - of the candidates in  $A$ . With the votes, the concept of a dictator is weakened. So, let  $g_k$ , a *limited dictator* over  $P(1, j)$ ,

be where  $s_k$  is either constant valued over this pair, or where  $c_1 > c_j$  is mapped either to  $c_1 > c_j$  or to  $c_1 = c_j$ . A corresponding definition defines a limited anti-dictator. A limited dictator may not be able to get outcomes better than, say,  $c_j > c_1$  and  $c_1 = c_j$ .

**Corollary 2.3.** Let  $n \geq 3$ ,  $N \geq 2$ , and  $F: (P(1, \dots, n))^N \rightarrow P(1, \dots, n)$  be given. For each pair  $(i, j)$ ,  $F$  satisfies the independence condition  $F: (P(i, j))^N \rightarrow P(i, j)$ . If  $F$  is nonconstant for each pair, then  $F$  is represented by a function of a single variable that corresponds to either a (limited) dictator or to a (limited) anti-dictator.

**Proof.** The same kind of induction argument used in the proof of Corollary 2.1 applies here. We only need to show that the new range satisfies the range overlap conditions. Start with  $R_1 = P(1, 2)$ ,  $R_2 = P(2, 3)$ , and  $R_3 = P(1, 3)$ . The rankings in the  $P(i, j)$  sets satisfy the range overlap conditions, so consider a pair with strict rankings and another pair with indifference. The set  $\{c_1 > c_2, c_1 = c_2\} \cap \{c_2 > c_3, c_3 > c_2\}$  contains  $\{c_1 = c_2 > c_3\}$  which are in different  $P(1, 3)$  sets. (See Figure 2.) Likewise,  $\{c_1 > c_2, c_1 = c_2\} \cap \{c_2 > c_3, c_3 = c_2\}$  contains  $\{c_1 = c_2 > c_3\}$  and  $\{c_1 = c_2 > c_3\}$  which are in different  $P(1, 3)$  sets. The range overlap conditions are satisfied. By symmetry, the conclusion holds for any triplet of indices. ■

Corollary 2.3 admits several situations ranging from a dictator to a limited dictator where  $c_1 > c_j$  is mapped to itself iff  $i < j$ ; otherwise it is mapped to  $c_1 = c_j$ . So for  $n=3$ , the image of  $F$  is the set of 4 rankings  $\{c_1 > c_2 > c_3, c_1 = c_2 > c_3, c_1 > c_2 = c_3, c_1 = c_2 = c_3\}$  rather than the 6 required in Theorem 1. By selectively allowing  $F$  to be constant over certain pairs, new situations emerge. For example, it is possible to have a local dictator over  $P(1, 2, 3)$  and a different, limited local dictator over  $P(3, 4, 5)$ .

The IIA conditions satisfy a monotonicity property; e.g., the group's relative ranking of  $\{c_1, c_j\}$  are determined only by the voters' relative rankings of these same two candidates. But, does this tacit assumption cause the impossibility conclusions? For instance, it would be interesting to determine whether we could get a possibility conclusion if the  $j$ 'th voter's relative ranking of, say,  $\{c_1, c_2\}$  affects the group's ranking of, say,  $\{c_2, c_3\}$ . Corollary 2.4 proves that nothing gained by this. It also shows that the independence assumptions can vary with the voter. (In Corollary 2.4a, if an index has a value greater than 3, then replace it with its remainder  $\{1, 2, 3\}$  when divided by 3; e.g., 7 is replaced with 1, and 9 with 3.)

Corollary 2.4. a. Let  $N \geq 2$  and  $F: P(1,2,3)^N \rightarrow P(1,2,3)$  be given. Let  $I^j(k) = P(c_{k+j-1}, c_{k+j})$ ,  $j=1,2,3$ ,  $k=1, \dots, N$ . Suppose that  $F$  is onto and satisfies the independence conditions  $F: I^j \rightarrow P(j, j+1)$ . There is an index  $s$  (voter  $s$ ) so that  $F$  is represented by a function of a single variable,  $g_s$ . There are only two possible ways to define  $g_s$ .

b. Let  $N \geq 2$ ,  $n \geq 3$ , and  $F: P(1, \dots, n)^N \rightarrow P(1, \dots, n)$  be given. For each  $k=1, \dots, N$ , let  $\pi^k(-)$  be a permutation of the indices  $\{1, \dots, N\}$  for the  $k^{\text{th}}$  voter, let  $I^{j,s}(k)$  be the set  $P(\pi^k(j), \pi^k(s))$ , and let  $I^{j,s} = \bigcap_k I^{j,s}(k)$ ,  $j, s = 1, \dots, N$ . If  $F$  satisfies the independence conditions  $F: I^{j,s} \rightarrow P^*(j,s)$  where  $F$  is not constant, then there is an index  $\beta$  (voter  $\beta$ ) so that  $F$  can be represented by a function of a single variable,  $g_\beta$ . There are only two possible ways to define  $g_\beta$ .

It is trivial to show that the overlap conditions are satisfied, so the corollary follows immediately from Theorem 2. Note,  $g_\beta$  need not be a dictator nor an anti-dictator. For instance, if  $s = 2$  in part a, then one choice has  $g_2$  taking  $c_j > c_k$  to  $c_{j+1} > c_{k+1}$ ; so,  $g(c_1 > c_2 > c_3) = c_2 > c_3 > c_1$ .

**Quasi-dictators**

$F$  need not be a mapping; it could be a correspondence where  $R$  is the power set of another set. Secondly, although  $F$  is represented by a single agent over  $I^1 \cap I^2 \cap I^3$ , it need not be over all of  $D$ .

**Example 3.** For  $N \geq 2$ , let  $F$  be a correspondence with domain  $P(1,2,3,4)^N$  and values in  $P(1,2,3,4)$ . Let  $I^j(k) = R^j = P(j, j+1)$  for  $j=2,3$ , and  $R^3 = I^3(k) = P(2,4)$ . If  $F$  satisfies the conditions  $F: I^j \rightarrow R^j$ ,  $j=1,2,3$ , and is onto for at least two choices of  $j$ , then, according to Theorem 2,  $F$  is represented by one agent over  $I^1 \cap I^2 \cap I^3$ . Each set in  $N^j I^j = P(2,3) \cap P(3,4) \cap P(2,4)$  admits both relative rankings of  $\{c_1, c_2\}$ , so this ranking could be determined by, say, a majority vote. Thus, a single voter determines the relative ranking of  $\{c_2, c_3, c_4\}$ , but  $\{c_1, c_2\}$  is ranked with a majority vote. ■

Example 3 and Theorem 2 explain why even when nondictatorial functions exist, often an agent is endowed with considerable power. This is because the independence conditions may not require a dictator to reign over all of  $D$ . She may be a dictator over the sizable portion  $N^j I^j$ , but only a quasi-dictator over all of  $D$ . This occurs in (Gibbard, Hylland, and Weymark [7]) where such a nondictatorial function exists if all feasible sets include  $c_1$ . The authors wonder if other situations exist. As we now know, this is the general case.

**Probability and Condorcet cycles**

If  $P = \{p = (p_1, \dots, p_6) \mid p_i \geq 0, \sum_{i=1}^6 p_i = 1\}$ , then  $P$  represents the space of probability distributions over the three candidates. If  $p$  has unity for some component (so all others are zero), then  $p$  represents the ranking of an agent. If  $p$  does not have unity for any component, then  $p$  can be viewed as an agent's probability distribution over the 6 rankings. Let  $Q_{i,j}$  represent the associated probability distributions,  $q = \{q_{1>j}, q_{j>1}\}$ , over the pair of candidates  $\{c_1, c_j\}$  where for  $p \in P$ ,  $q_{1>j} = \sum p_a$  -- the summation is over those three components of  $p$  associated with  $c_1 > c_j$ . Of course, many choices of  $p$  may define the same  $q$ , so let  $\Phi(q; i, j) = \{p \in P \mid p \text{ defines } q \in Q_{i,j}\}$ .  $q \in Q_{i,j}$  admits the interpretation of being the agent's probability distribution over the relative ranking of the pair  $\{c_1, c_j\}$ .

For each  $k = 1, \dots, N$ , let  $D_k$  be a subset of  $P$  where  $|D_k| \geq 6$  and for  $a = 1, \dots, 6$ , there is  $p \in D_k$  where  $p_a > p_i$ . Let  $Q_{i,j}(k)$  be the subset of  $Q_{i,j}$  associated with  $D_k$ . We say that  $D_k$  is full if for each  $q' \in Q_{i,j}(k)$ ,  $D_k \cap \Phi(q'; i, j)$  meets  $D_k \cap \Phi(q; s, t)$  for every pair  $(s, t) \neq (i, j)$  and  $q \in I_{s,t}$ . An example of a full  $D_k$  is where each  $p \in D_k$  has unity as a component. As another example, select  $p \in P$  where not all components are the same, and let  $D_k$  consist of the 6! permutations of  $p$ .

Corollary 2.5a extends the Condorcet cycle, which has played an important role in social choice, from a statement concerning majority vote to a statement that includes assertions about probability, or about voting models where voters are uncertain about their rankings. (The Condorcet cycle corresponds to where each  $p \in D_k$  has unity for some component and  $F_{i,j}$  is a summation.) Part b extends Arrow's Theorem to a statement over probability measures. As the choice of  $D_k$  can differ with  $k$ , it also illustrates that the domain for each agent can differ. Part c explains and extends the well-known Steinhaus-Trybula paradox [23] from a statement about probabilities to all measures including expected values, variances, etc.

Corollary 2.5. Let  $N \geq 2$ ,  $n = 3$ , and  $D_k$  be full for  $k = 1, \dots, N$ .

- a. For each  $(i, j)$ , a nonconstant mapping  $F_{i,j}: X^k \rightarrow P^{\sim}(i, j)$  defines a binary ranking for  $\{c_1, c_j\}$ . If the binary rankings always are transitive, then each  $F_{i,j}$  is represented as a function of the same single variable.
- b. If  $F: D = D_1 \times \dots \times D_N \rightarrow P^{\sim}(1, 2, 3)$ , satisfies the nonconstant independence condition  $F: X^k \rightarrow Q_{i,j}(k)$  for each  $(i, j)$ , then  $F$  is represented by a function of a single variable.

c. Let  $N = 1$ , and let non-constant mappings  $F_{1,j}: Q_{1,j} \rightarrow P_{1,j}$  be given. There exist  $p \in P$  so that the binary rankings are not transitive.

**Proof.** The range overlap conditions of parts a, b and c are satisfied, so only the domain conditions need to be checked. For parts a, b and for  $(i,j)$ , consider any two domain points that give different  $F_{1,j}$  images. For each  $k$ , let the  $k$ th component of each point define the class  $I_{1,j}(k)$ . Notice, for some values of  $k$  it may be that  $I_{1,j}(k,1) = I_{1,j}(k,2)$ , but at least one value of  $k$  has  $I_{1,j}(k,1) \neq I_{1,j}(k,2)$ . The overlap conditions now follow from the fullness condition. The conclusion follows from Theorem 2. For part c, let  $G(p_1, p_2): P \rightarrow P$  be  $(p_1 + p_2)/2$ . By linearity,  $G: Q_{1,j} \times Q_{1,j} \rightarrow Q_{1,j}$ . So, the composition of  $F_{1,j}$  with  $G$  provides a two agent version. The conclusion follows from part a.

**Sen's Theorem**

When  $I_j(k,1) = I_j(k,2)$ , the  $k$ th voter has no influence over which  $R_j$  class is selected. (Here, as  $I_j$  admits only one  $I_j(k)$  component, it is a fixed value. Thus, voter  $k$  cannot vary any variables influencing the value of  $F: I_j \rightarrow R_j$ ; i.e.,  $\Delta^k F_j = 0$ .) Corollary 2.6 illustrates how such a condition can be used with Theorem 2. Part a asserts there does not exist a social welfare function where the first agent determines the group ranking of  $c_1$  and  $c_2$ , the second agent determines the ranking of  $c_2$  and  $c_3$ , while the third agent determines the ranking of  $c_1$  and  $c_3$ . Part b asserts that if each agent is modelled to have no influence over only one pair, then  $F$  cannot be onto. Part c extends Sen's theorem [22] about a Pareto liberal where two agents have the privileged status to determine the relative ranking of certain alternatives - presumably their own - while the other alternatives are represented only through a weak pareto condition.

**Definition.** Let  $F: P(1, \dots, n)^N \rightarrow P(1, \dots, n)$  be given.  $F$  satisfies the weak Pareto condition for  $\{c_j, c_k\}$  if  $F((c_j > c_k)^N) = c_j > c_k$  and  $F((c_k > c_j)^N) = c_k > c_j$ . Namely, if everyone has the same ranking of  $\{c_j, c_k\}$ ,  $F$  preserves this relative ranking.

**Corollary 2.6.** a. Let  $N=3$  and  $F: P(1,2,3)^3 \rightarrow P(1,2,3)$  be given. Let  $I_j(k) = P(c_j, c_{j+1})$  iff  $k=j$ ; otherwise let  $I_j(k,1) = I_j(k,2)$ . Let  $R_j = P^{\sim}(c_j, c_{j+1})$ . If  $F$  satisfies the independence conditions  $F: I_j \rightarrow R_j$ ,  $j=1,2,3$ , then  $F$  has a fixed ranking for at least two of the pairs.

b. Let  $N \geq 2$  and let  $F: P(1, 2, 3)^N \rightarrow P(1, 2, 3)$  be given. For each  $k$ , let one of the  $I_j(k)$  equivalence class be a singleton and the other two  $I_j(k) = P(j, j+1)$ . If  $F$  exists, it is constant valued for at least two pairs. c. Let  $n \geq 3$ ,  $N \geq 2$ . Let  $A_1, A_2, A_3$  be subsets of the indices  $\{1, \dots, n\}$  where  $|A_j| \geq 2$  and each pair of these sets have a different, but unique index in common. There does not exist an  $F: P(1, \dots, n) \rightarrow P(1, \dots, n)$  such that: 1) the  $P(A_j)$  image of  $F$  is nonconstant and it depends solely upon the  $j$ th voter's rankings of the  $A_j$  candidates,  $j=1, 2$ , and 2)  $F$  satisfies the weak pareto condition for the pairs of alternatives in  $A_3$ .

If  $|A_1 A_2| \geq 2$  in  $c$ , then an argument like that for parts a and b shows that  $F$  does not exist. An induction argument, similar to that used in Corollary 2.1, extends this statement to a larger number of  $A_j$  sets. **Proof.** a. The overlap conditions are satisfied, so, if  $F$  is nonconstant over two or more binaries,  $F$  can be represented by a function of a single variable. By assumption, this is impossible. This completes the proof of part a. Part b follows from the last sentence of Theorem 2. For part c, assume that  $c_1, c_2$ , and  $c_3$  are, respectively, the common elements for  $A_1$  and  $A_2$ , for  $A_2$  and  $A_3$ , and for  $A_3$  and  $A_1$ . The weak pareto condition corresponds to the interpersonal condition  $E_{1,3}(\{1, \dots, N\}) = (c_3 > c_1) \cup (c_1 > c_3)^N$ . Let  $I_1(1) = P(1, 2), I_2(2) = P(2, 3), I_3(3) = P(1, 3)$ , and all other  $I_k(j)$  sets are singletons; the whole set  $P(1, 2, 3)$ . The domain overlap conditions are satisfied, so, according to Theorem 2, if such an  $F$  exists, it is determined by one voter. This contradicts the first assumption. ■

**The Kalai, Muller, Satterthwaite's Theorem**

The next result extends the Kalai, Muller, Satterthwaite Theorem (KMS) concerning  $U^n$  - the smooth, concave, monotonic utility functions over a space of  $n$  public goods,  $R^n_+$ . As KMS note,  $U^n$  -- a standard set for economic and political models -- is a small subset of all possible transitive rankings over  $R^n_+$ . They wonder whether it is sufficiently restrictive to escape a dictator, and then they show that it is not. Stronger conclusions (Corollary 2.7, 2.8) follow from Theorem 2.

Let  $T(S)$  be the set of all complete, binary, transitive rankings of the elements of  $S$ . The object is to find

$$3.4 \quad F: \prod_{i=1}^n T(R^n_+) \rightarrow T(R^n_+)$$

that satisfies the following IIA condition. For a subset  $B$  of  $R^n_+$ , let  $\prod_{i=1}^n B = \{u \in \prod_{i=1}^n u_i \mid u_i \text{ is restricted to } B\}$  while  $T(R^n_+|B)$  denotes rankings in  $T(R^n_+)$  restricted to  $B$ . The IIA condition of KMS is that for all  $B$ ,  $F$  satisfies

3.5  $F: (U \times B) \times (U \times B) \rightarrow T(R^n^+ | B)$ .

A weaker assumption than the KMS condition of unanimity is the non-

constant assumption that if  $B$  contains two points,  $x, y$ , that do not dominate

each other (i.e., each component of one vector is not an upper bound for the

corresponding component of the other vector), then, in Eq. 3.5,  $F$  is not

constant valued.

**Corollary 2.7.** For  $N, n \geq 2$ , if  $F$  given by Eq. 3.4 satisfies the non-constant,

IIA condition Eq. 3.5, then  $F$  can be represented by a function of a single

variable.

**Proof.** Assume  $F$  exists and let  $x_j, j = 1, 2, 3$ , be points in  $R^n^+$  where

each point does not dominate either of the other two. For  $B = \{x_1, x_j\}$ , we have

$T(R^n | B) = P^*(i, j)$ . These sets satisfy the range overlap condition. It remains

to show that the domain overlap conditions, which involve sets of utility

functions, are satisfied. The idea is similar to that in Section 1 and it is

illustrated in Figure 3. Let  $I_{i,j}(k, l > j) = \{u \in U^n | \text{an indifference set passing}$

through  $x_i$  is above  $x_j\}$ , while  $I_{i,j}(k, j > l)$  has the indifference set through  $x_j$

above  $x_i$ . In Figure 3, there are three indifference sets for the same utility

function  $u$ . The first one passes through  $x_1$  and above  $x_2$ , so  $u \in I_{1,2}(k, l > 2)$ .

The second indifference set passes through  $x_2$ , but below  $x_1$  and  $x_3$ , so  $u \in$

$I_{1,2}(k, l > 2) \cap I_{2,3}(k, l > 2)$ . Notice the flexibility in the design of the

indifference set passing through  $x_3$ ; one choice has it passing above  $x_1$  (so  $u \in$

$I_{1,3}(k, l > 1)$ ) and another choice has it passing below  $x_1$  (so  $u \in I_{1,3}(k, l > 3)$ ).

This is one of the overlap conditions. The others are derived in a similar

fashion. ■

### Derivative conditions and the weak axiom of revealed preference

Can the KMS theorem be circumvented with different kinds of economic

information? For instance, the price mechanism depends on the gradients of the

utility functions; can the gradient be used to define transitive outcomes? The

next definition permits  $F$  to depend on the first  $B$  derivatives of the utility

function at a point. Let the jet,  $J_B(u, x)$ , be  $(x, u(x))$  and the first  $B$  terms

in the Taylor series of  $u$  at  $x$ , let  $J_B(u) = \{J_B(u, x) | x \in R^n^+\}$ , and let  $J_B(U) =$

$\{J_B(u) | u \in U\}$ . The jet  $J_B(u, x)$  is an element of the space  $L_B =$

$R^n \times R^k \times R^n \times R^{n(n+1)/2} \times \dots$  where  $x \in R^n^+, u(x) \in R, \nabla u(x) \in R^n, \dots$ . The object

is to find a mapping

3.6  $F: (J_B(U))^N \rightarrow T(L_B)$

that satisfies the following IIA condition. For a subset  $B$  of  $L_B$ , let  $J_B(U) | B$

be the restriction to  $B$ . The IIA condition is that for all  $B$ ,  $F$  satisfies

$$3.7 \quad F: (P(A_j) \times S(A_j)) \rightarrow T(L^n|B).$$

An example of this for  $B, N = 1$ , is the revealed preference relationship

satisfied by Marshallian demand. (See Varian [24, p101].) The vector

$\Delta u(x)/|\Delta u(x)|$  determines the normalized price  $p$  associated with the demand  $x$ . If  $B = \{x_1, x_2\}$ , two distinct demand bundles, then  $x_1 >_{RP} x_2$  iff  $p_1 \cdot (x_1 - x_2) > 0$ . (The inequality is strict because  $u \in U^n$ .) As it is well known,  $>_{RP}$  is transitive. As another example, let  $B = \{v_1, v_2: v_1 \in \mathbb{R}^n, |v_1| = 1\}$  represent two different normalized prices. Here, one choice for  $F|B$  is the excess demand at the two different prices.

The next general condition replaces "unanimity." Let  $Q$  be a set of at

least three pairs of listings  $a = (x, y, v, \dots) \in L^B$  where if  $B_j$ ,  $j=1, 2, 3$ , are the pairs corresponding to three listings in  $Q$ , then  $T(L^n|B_j)$  satisfy the range overlap conditions. The IIA condition is  $Q$  non-constant if when  $B$  contains a pair from  $Q$ , then Eq. 3.7 is non-constant. Thus, the  $Q$  condition admits models where the focus is on demand, prices, concavity, initial allocations, etc.

Corollary 2.8. a. Let  $N \geq 2$  and  $F$  satisfy Eq. 3.6 with a  $Q$  non-constant IIA condition Eq. 3.7.  $F$  is represented by a function of a single variable. b. For  $N=2$ , if  $>_{RP}$  is defined as above by the aggregate demand bundles, then it is not always transitive.

The proof is immediate.

### Social Choice Functions

To see how Theorem 2 includes social choice theorems, for  $C^n = \{c_1, \dots, c_n\}$  let  $A_j, j=1, \dots, p$ , be specified subsets of  $C^n$  where  $FS = \{A_1, \dots, A_p\}$  are the feasible sets of  $C^n$ . Let  $S(A)$  be the set of all nonempty subsets of  $A$ . A social choice correspondence,  $F: FS \times P(1, \dots, n) \rightarrow S(C^n)$ , assigns to a

feasible set  $A_j$  and  $x \in P(1, \dots, n)$  a subset from  $S(A_j)$ .  $F$  satisfies independence of infeasible alternatives (IIA) if for  $A_j \in FS$ , and for  $x, y \in P(1, \dots, n)$  that agree on  $A_j$  (they are in the same  $P(A_j)^N$  class),  $F(A_j, x) = F(A_j, y)$ . A social choice correspondence  $F$  is strictly nonconstant over  $A_j$  if the image of  $F(A_j, -)$  has at least two disjoint, nonempty subsets.  $F$  satisfies the choice axiom if, for all  $x, F(A_j, x) = F(C^n, x) \cap A_j$ . The definition of a

correspondence of a single variable, a dictator, and an anti-dictator are the obvious ones. The difference between a social welfare function and a social choice



function is that a social welfare function determines a ranking of the candidates, while the social choice function selects only the "best" candidates. If a social welfare function exists, the related social choice function selects the top ranked candidate(s): the social choice function is realized by the social welfare function. Hansson [9] characterizes the social choice functions that can be realized. While the conditions given below invoke Hansson's theorem, the conclusions are proved directly to illustrate how Theorem 2 includes social choice models.

**Corollary 2.9.** For  $N \geq 2$  and  $C^n$  for  $n \geq 3$ , let the set of feasible sets include  $C^n$  and all of its two element subsets. Let  $F$ , a social choice correspondence, satisfy IIA, the choice axiom, and is strictly nonconstant over the pairs of alternatives.  $F$  is represented by a function of a single variable. Corollary 2.4 and some of the other statements.

**Proof.** As with Corollary 2.1, the proof is by induction. Choose three candidates, say  $\{c_1, c_2, c_3\}$ . Assume that  $A_j = \{c_j, c_{j+1}\}$ . Let  $I^j(k) = P(j, j+1)$ , and define  $R_j$  to be  $\{c_j, A_j, c_{j+1}, A_j, c_j\}$  where  $A_j$  is the complement of  $A_k$  in  $A$ . (So, if  $n=3$ ,  $R_1 = \{c_1, c_3, c_2, c_3\}$ .) It follows from IIA and the choice axiom that  $F: I^j \rightarrow R_j$ . It is easy to show that the sets  $R_k$  satisfy the range overlap conditions; e.g., for  $n=3$ ,  $R_1 \cap R_2 = \{c_1, c_3, c_2, c_3\} \cap \{c_2, c_1, c_3, c_1\} = \{c_3, c_1\}$ ,  $\{c_1, c_3\}$ ,  $\{c_2, c_3\}$ , so the first two sets are in different  $R^3$  subsets. The conclusion follows from Theorem 2.

**Gibbard - Satterthwaite**

As a last illustration of Theorem 2, I prove the Gibbard-Satterthwaite theorem in a way that differs from the standard "distribution of power" approach. The two main features of this proof are to illustrate how monotonicity conditions implicitly define the independence conditions  $I^j$  and how each step of the proof can be viewed as carrying out the discrete analog of the natural "calculus argument." (In other words, the calculus argument provides an outline for the proof. The italicized comments describe the steps of the calculus approach.) For simplicity of exposition, only three alternatives are considered. (In much the same manner as described for the earlier corollaries, the results extend to all values of  $n \geq 3$  and to all subsets of  $C^n$ .)

For  $C^3$ , a voting scheme is a function  $F: P(1,2,3)^N \rightarrow S(C^3)$ . A  $x_j \in P(1,2,3)$  admits the binary relationship  $c_1 >_j c_k$  iff this is the relative ranking

of the two candidates in  $x_j$ . A voting scheme is *manipulable* iff there exists  $x, y \in \{P(1,2,3)\}^N$  that differ only in the  $j$ th component where  $F(y) >_j F(x)$ . If the  $j$ th component for  $y$  is  $y_j$ , then we say that  $j$  manipulates  $F$  at  $x$  with  $y_j$ .

**Corollary 2.10 (Gibbard-Satterthwaite).** Let  $F$  be a voting scheme from  $\{P(1,2,3)\}^N$  to  $C^3$  where  $F$  is onto.  $F$  is either dictatorial or manipulable.

**Proof.** Assume  $F$  is not manipulable; we show it is dictatorial. For  $A_{1,j} = \{c_1, c_j\}$ , let  $R_{1,j} = \{\{c_1, A'_{1,j,j}\}, \{c_j, A'_{1,j,j}\}\}$ ; e.g.,  $R_{1,2} = \{\{c_1, c_3\}, \{c_2, c_3\}\}$ . The range overlap conditions are satisfied. Corollary 2.10 follows from Theorem 2 if the  $I_{1,j}(k)$  sets are  $P(1,j)$ . To emphasize the ideas, the proof is divided into three lemmas. First, note that  $F^{-1}(c_j) \neq \emptyset$  for all  $j$ .

(If the induced mapping  $F^1$  were smooth, we would use the assumption  $F$  is not manipulable to determine  $\Delta F_{1,j} = (\Delta^1 F_{1,j}, \dots, \Delta^N F_{1,j})$ . Namely, we would consider the directional derivatives  $(\Delta^k F_{1,j}, v^k)$  where  $v^k$  corresponds to variations in the preferences. Part a of Lemma 1 shows that  $\Delta^k F_{1,j}$  is orthogonal to  $P(1,j)$  level sets, while the second part establishes the orientation of  $\Delta^k F_{1,j}$ .)

**Lemma 1.** If  $F(x) = c_j$  and if  $x = (x_1, \dots, x_N)$  varies only in the  $k$ th component where this variable,  $y_k$ , varies in the same  $P(1,j)$  class, then  $F$  remains in the same  $R_{1,j}$  class. If when  $y_k$  changes  $P(1,j)$  classes, the image of  $F$  changes  $R_{1,j}$  classes, then the change is monotonic; e.g., if  $y_k$  moves from  $P(c_j > c_1)$  to  $P(c_1 > c_j)$ , then the image of  $F$  moves from  $\{c_j, c_k\}$  to  $\{c_1, c_k\}$ .

**Proof.** Let  $k = 1$ . Suppose the first part of the lemma is false because the image of  $F$  changes  $R_{1,j}$  classes when this voter changes to  $y_1$ , where both  $x_1$  and  $y_1$  are in the same  $P(1,2)$  class. If this voter's relative ranking is  $c_1 > c_j$ , he can manipulate the outcome of  $F$  at  $x$  with  $y_1$ ; otherwise he can manipulate the outcome of  $F$  at  $(y_1, x_2, \dots, x_N)$  with  $x_1$ . Both contradict the assumption that  $F$  is not manipulable. Similarly, if changing the  $P(1,j)$  classes has the reversed effect on the image, then either one way, of the other, the first agent can manipulate the outcome. If this agent's relative ranking is  $c_1 > c_j$ , then  $F$  is manipulated at  $x$  with  $y_1$ ; otherwise  $F$  is manipulated at  $(y_1, x_2, \dots, x_N)$  via  $x_1$ . ■

(To finish characterizing  $\Delta^k F_{1,j}$  we consider directional derivatives in directions not involving  $c_j$ .)

**Definition.** The change of a ranking  $x_1$  to  $y_1$  is called a  $c_j$  restricted change if for each  $c_k, c_k > c_j$  in  $x_1$  iff the same relative ranking holds in  $y_1$ .

A  $c_j$  restricted change requires all of the candidates ranked above  $c_j$  in  $x_i$  to be ranked above  $c_j$  in  $y_i$ , and vice versa. Such a change does not affect the relative ranking of  $c_j$  with any other candidate. For instance, going from  $c_1 > c_2 > c_3$  to  $c_2 > c_1 > c_3$  is a  $c_3$  restricted change, but not a  $c_2$  restricted change.

**Lemma 2.** If  $F(x) = c_j$ , and  $y$  differs from  $x$  only in the  $k$ th voters ranking which is a  $c_j$  restricted change, then  $F(y) = c_j$ .

*Proof.* Assume false, and that  $F(y) = c_i$ . Agent  $k$  made a  $c_j$  restricted change, so her relative ranking of  $c_i$  and  $c_j$  remains the same. Thus, she can manipulate  $F$  either at  $x$  with  $y-x$ , or at  $y$  with  $x-y$ . ■

(Lemmas 1 & 2 characterize the components of  $\Delta F_{i,j}$ ; Lemma 3 uses this information to determine the level sets of the components of  $F^1$ .)

**Lemma 3.** For each  $i$  and  $j$ ,  $F: I_{i,j} \rightarrow R_{i,j}$ .

*Proof.* Assume false for, say,  $(i,j) = (1,2)$ . Thus, there are  $x, y$  in the same  $(P(1,2))^N$  class where  $F(x) = c_1$  and  $F(y) = c_2$ . As  $x$  and  $y$  are

connected by a series of individual ranking changes in the same  $P(1,2)$  class, it follows from Lemma 1 that there must be an intermediate profile,  $z$ , in the same  $P(1,2)^N$  class, where  $F(z) = c_3$ . Assume each agent's ranking in  $x$  with

$c_1 > c_3$  is  $c_1 > c_3 > c_2$  or  $c_2 > c_1 > c_3$ . (If not, this can be achieved with  $c_1$

restricted changes.) According to Lemma 1, if a  $P(1,2)$  invariant change alters the outcome to  $c_3$ , it is because there were  $P(1,3)$  changes for a subset of

these voters; let  $V_{1,3}$  be the indices of these voters, and let  $z'$  be the new profile. (Notice, these involve  $c_2$  restricted changes where  $c_1 > c_3$  is changed

to  $c_3 > c_1$ .) To change the image from  $c_3$  to  $c_2$ , certain voters stay in the same  $P(1,2)$  class while changing  $P(2,3)$  classes from  $c_3 > c_2$  to  $c_2 > c_3$ . Let  $V_{2,3}$  be

the indices of these voters and let  $y$  be the profile. We can assume that  $V_{1,2}$  and  $V_{2,3}$  are disjoint. (This is because the voters with the  $x$  ranking of

$c_2 > c_1 > c_3$  have the wrong  $P(2,3)$  ranking to make this change.) For the other voters in  $V_{1,2}$ , the  $P(1,3)$  change results in  $c_1 > c_3$ . If this doesn't change the

image to  $c_1$  (the only possibility), then this voter wasn't needed in  $V_{1,2}$ . If it does, then, according to Lemma 1, the next  $P(2,3)$  change cannot change

the outcome to  $c_2$ .

Change  $y$  to  $w$  by using a  $c_2$  restricted change for all indices in  $V_{1,2}$ . According to Lemma 2,  $F(y) = F(w) = c_2$ . Profile  $x$  differs from  $w$  only for the

rankings of the  $V_{2,3}$  voters. So, the changes from  $x$  to  $w$  only involve  $P(2,3)$  changes in the same  $P(1,2)$  and the same  $P(2,3)$  classes. Thus, according to

Lemma 1,  $F(w)$  is in  $\{c_1, c_3\}$ . ■

Corollary 2.10 follows from Lemma 3 and Theorem 2. ■

4. Possibility Theorems.

To conclude, I derive the sharpest possible "possibility results" that can be obtained by domain restrictions. Essentially, the main result (Theorem 3) asserts that if just one agent is restricted from assuming just one ranking, then a possibility theorem holds. Thus, Theorem 3 extends the nice work of Kalai and his coauthors Muller and Ritz [13,14] in several ways. First, [13,14] considers traditional social welfare mappings based on preferences for a finite number of candidates; Theorem 3 holds for "classes of axioms" so it includes models with utility functions (as the KMS theorem), probability measures, etc. In [13,14] each agent must have the same restrictions; here different restrictions can be imposed on different agents.

Theorem 3 answers a puzzling social choice phenomenon. When domain restrictions permit possibility theorems, it is reasonable to expect that stronger restrictions result in models with more voter participation. This need not happen; stronger restrictions can force a return to an impossibility conclusion! For instance, using a KMS model, Donaldson and Weymark [4] obtained a possibility theorem with an independence condition that models a form of "free disposal of goods." Yet, with a further restriction, an impossibility theorem emerged. To see why this kind of behavior occurs, consider Arrow's theorem where one voter,  $\beta$ , can assume any ranking except  $c_1 > c_2 > c_3$ . According to Theorem 3, a possibility theorem emerges. But, if  $\beta$ 's rankings are further restricted to  $\{c_1 > c_3 > c_2, c_3 > c_1 > c_2\}$ , a dictator other than  $\beta$  arises. This is because with the original restriction, each of the three independence classes are the two  $P(i,k)$  sets minus  $c_1 > c_2 > c_3$ . Because this ranking is missing, the domain overlap conditions are not satisfied, so, as Theorem 3 asserts, a possibility conclusion holds. On the other hand, the stronger restrictions on  $\beta$ 's rankings create a new set of  $I(\beta)$  classes. One class is  $P(1,3)$ . But now  $\beta$  is allowed in only one  $P(1,2)$  and one  $P(2,3)$  class, so the two new  $I$  independence classes are these singletons. Theorem 2 applies because the stronger restrictions (or more relaxed independence conditions) create domain independence sets that do satisfy Theorem 2. The next definition, used in Theorem 3, captures this behavior.

**Definition.** Let  $\{I_j(k)\}$ ,  $j=1,2,3$ , satisfy the restricted domain overlap conditions for  $D_k$ . A restriction for the  $k$ th voter is a proper subset,  $C_k$ , of  $I_1(k) \cup I_2(k) \cup I_3(k)$ . The independence classes  $\{I_j(k)\}$ ,  $j=1,2,3$ , are  $C_k$  equivalent

to  $\{j(k)\}$  when the following holds:  $x \in j(k,s) \cap C_k$  iff  $x \in j(k,s) \cap C_k$ ,  $j = 1,2,3$ ,  $s = 1,2$ .

As an example, let  $I_{1,j}(k) = P(c_1 > c_j)$ ,  $P(c_j > c_1)$  and  $C_k = \{c_1 > c_2 > c_3, c_1 > c_3 > c_2, c_3 > c_1 > c_2\}$ ; i.e.,  $C_k = \{A,B,C\}$  in Figure 2. The sets

$I_{1,j}(k) = I_{1,j}(k)$  for  $(1,j) = \{(1,3), (2,3)\}$ , and  $I_{1,2} = P(c_1 > c_2)$  are  $C_k$

equivalent to the original set. Namely,  $C_k$  forces one  $I_{1,2}(k)$  sets to be

empty, so the new set  $I_{1,2}(k)$  has the nonempty set as a singleton. With the restriction  $C_k$ , the implicitly defined classes do not satisfy the domain

overlap conditions.  $(I_{1,2}(k) \cap I_{2,3}(k) = I_{2,3}(k) \cap C_k = \{c_1 > c_2 > c_3\}, \{c_1 > c_3 > c_2, c_3 > c_1 > c_2\})$ , so there are no two sets in this intersection where each meets both  $I_{1,3}(k)$  sets.)

**Theorem 3.** Let  $\{F, I_j(k)\}$ ,  $j=1,2,3$ , satisfy the conditions of Theorem 2.

Let restrictions be imposed on at least one of the voters, say 1, that

satisfies the restricted domain condition. Suppose that all independence

classes  $\{I_j(k)\}$  that are equivalent to  $\{I_j(k)\}$  with respect to the restrictions

cannot be singletons for at least two values of  $k$  and they satisfy one of the

following. a) For agent 1, the sets fail to satisfy the domain overlap

conditions. b)  $\{I_j(1)\}$  has only two classes with two disjoint nonempty sets,

say  $I_j(1)$ ,  $j=1,2$ , and at least two of the four sets in  $I_j(1) \cup I_j(2)$  are empty.

There exists a function  $F$  from the restricted domain of  $D$  to  $R$  that satisfies

the independence conditions  $F: I_j \rightarrow R$ ,  $j=1,2,3$ , where  $F$  is non-constant for at

least two values of  $j$  and  $F$  cannot be represented as a function of a single

variable.

In other words, if the restrictions do not admit independence conditions that require, via Theorem 2, a dictatorial situation, then a non-dictatorial  $F$  exists.

**Corollary 3.1.** Let  $n=3$  and  $I_{1,j}(k) = R$ ,  $j = P(1,j)$ . If  $C_1$ , the restrictions on voter 1, are such that  $C_1 \cap I_{1,j}(1,s) \neq \emptyset$  for all  $(1,j)$ ,  $s = 1,2$ , then there exists a mapping from this restricted domain that cannot be represented by a function of a single variable.

**Example 4.**  $C_1 = \{c_1 > c_2 > c_3, c_3 > c_2 > c_1\}$  admits a social welfare function that is not governed by an (anti) dictator because each  $P(1,j)$  set meets  $C_1$ . On the other hand, the restrictions  $C_1' = (c_1 > c_2 > c_3, c_2 > c_1 > c_3)$  cannot avoid a dictatorial situation because  $C_1'$  meets only one set in each of  $P(2,3)$  and

$P(1,3)$ . As a result, both of these classes can be replaced with a singleton set. The overlap conditions are satisfied and Theorem 2 holds. ■

Theorem 3 requires just one agent to be restricted from just one ranking to allow a possibility theorem. But the resulting  $F$  need not be a model of participatory democracy; one agent can still dictate the ranking of certain pairs. To see why, let  $n=3$  and let voter 1 assume all rankings except  $\{c_1 > c_3 > c_2\}$  (i.e.,  $C_1 = P(1,2,3) \setminus \{c_1 > c_3 > c_2\}$ ) where there are no restrictions on the other voters. If  $F$  is not a function of a single variable, then voter 1 must influence the outcome of two pairs. This is because if he never affects the outcome of a particular pair, then his independence class for this pair is implicitly redefined to a singleton. If this is true for two pairs, then the newly defined classes trivially satisfy the domain overlap condition, and Theorem 2 applies.

As  $C_1$  permits voter 1 to change  $P(1,3)$  and  $P(2,3)$  classes, a slight variation of the argument for Theorem 1 shows that voter 1 determines the outcome of these pairs. This forces the definition of  $F$  upon us; voter 1 must determine the  $P(1,3)$  and  $P(2,3)$  outcomes. Using Figure 2, these outcomes are either  $P(c_3 > c_1 > c_2)$  or  $P(c_1 > c_3 > c_2)$  or  $P(c_1 > c_2 > c_3)$  or  $P(c_2 > c_3 > c_1)$ . These sets do not define the  $P(1,2)$  outcome, so it can be determined in any desired manner by all voters, say, with a majority vote. The one exception is when voter 1 has the ranking  $c_2 > c_3 > c_1$ . Here the  $P(1,3)NP(2,3)$  image is either the anti-

how voter 1 determines the image of  $F$ . Thus, if voter 1 has the ranking  $c_2 > c_1$ , he determines the  $P(1,2)$  outcome. Otherwise the  $P(1,2)$  image is determined by a majority vote of the remaining voters. Namely,  $F$  has the same  $\{c_1, c_2\}$  ranking as voter 1 except when he has the ranking  $c_1 > c_2$ ; here the  $\{c_1, c_2\}$  ranking is determined by a majority vote.

With this construction, one can imagine that other  $F$ 's arise with the appropriate domain restrictions. For instance, certain domain restrictions may permit voter 1 to uniquely determine the  $P(1,2)$  and  $P(2,3)$  outcomes, voter 2 to determine the  $P(1,4)$ ,  $P(1,5)$  outcomes, ... An iterative application of Corollary 3.2 leads to such constructions.

**Corollary 3.2. a.** Let  $N \geq 2$ . Suppose the independence classes and the division of the range for given  $D$  and  $R$  satisfy the overlap principle. Let voter 1 satisfy the restricted domain overlap conditions, and impose the restrict  $C_1$ . Suppose  $C_1$  is such that there is a permutation  $(a,b,c)$  of  $(1,2,3)$  so that  $\{a(1) \cup b(1)\}$  has two sets where each meets both  $C(1)$  sets. If  $F$  cannot be

represented by a function of one variable, then voter 1 determines the  $R^a$  and  $R^b$  outcome.

b. Let  $N=2$ , and let restrictions  $C_1$  and  $C_2$  be given. Suppose for two different permutations  $(a(k), b(k), c(k))$ , that  $I^{a(k)} \cap I^{b(k)}$  contains two sets that meet both  $I^{c(k)}$  sets but the other sets in this intersection do not. If  $I^a$  is not a function of a single variable, then one voter,  $k$ , determines the  $R^{a(k)}$  and the  $R^{b(k)}$  outcomes.

**The Hurwicz-Schmidler Theorem**

As a final example, I recapture some of Hurwicz and Schmidler's (HS) nice results about inferior Nash equilibria. (In this way I relate HS's results to Arrow's theorem.) HS studied games, or allocation processes, with a finite number of alternatives, where, for each profile, there is a Nash equilibrium that is Pareto optimal. Such an allocation procedure is *acceptable* [11, p. 1447]. HS showed that, for  $N=2$  agents, an acceptable allocation function is dictatorial, but that the same conclusion does not hold for  $N \geq 3$ . To illustrate Corollary 3.2, I show why the dictatorship occurs for  $N=2$ . Consider allocation procedures with two outcomes,  $\{a, b\}$ , and two agents. The range space is *not* just the outcomes; it is each outcome associated with how each agent honestly ranks the alternatives. For instance, typical outcomes are  $\{a, a\}$ ,  $\{a, b\}$ ,  $\{b, a\}$ , and  $\{b, b\}$ . The first outcome is where "a" is the selected alternative, agent 1's top ranked alternative, and agent 2's bottom ranked alternative. The second and third outcomes do not occur because of the *pareto condition*. For instance, in the second outcome, both agents prefer the available alternative  $b$ . The remaining 6 outcomes satisfy the pareto condition and are represented in Figure 4. In this triangle, the edge to the left represents the first voter's true ranking and defines the two  $R^1$  classes, the edge to the right represents the second voter's true rankings and defines the two  $R^2$  classes, while the bottom edge denotes the selected alternative and determines the two  $R^3$  classes. The domain for each agent,  $D_k$ , is represented by the triangle but with a different interpretation. The bottom edge is this agent's two strategies where "a" represents the best response to get "a" adopted. (For instance, if  $f(b, b) = a$ , "a" may represent her saying "b.") This defines the  $I^3(k)$  classes. The  $I^j(j)$  classes agree with the  $R^j$  classes,  $j=1, 2$ . The remaining equivalence class for each agent consists on what the agent *believes* is the true ranking of the opponent. For instance,  $(a_1, b_1, a_2, b_2)$  is where voter 1 uses a strategy to achieve  $a$  when his first choice is  $b$ , and he believes that agent 2's true first choice is  $b$ . This point and  $(b_1, a_1, b_2, a_2)$  are not admitted because of the

Nash and Pareto assumptions. The remaining 6 points are represented in the triangle. Augment the allocation function,  $f: \{a, b\}^2 \rightarrow \{a, b\}$ , to define the mapping  $F: D_1 \times D_2 \rightarrow R_j$ , in the natural manner. Namely,  $F$  map  $I_j(j)$  to  $R_j$ ,  $j=1, 2$ , and  $f$  maps the strategies to the  $R_3$  class. By construction,  $F: I_j \rightarrow R_j$ ,  $j=1, 2, 3$ .

The range overlap conditions are satisfied, so it remains to show that  $F: I_j \rightarrow R_j$  is onto for at least two choices of  $j$ . (This is not immediate because  $F$  has only four image points.) By the Pareto assumption,  $F$  must have an image in regions  $B$  and  $E$ . There is an outcome for each profile, so there is an image point in  $\{C, D\}$  and in  $\{A, F\}$ . If the two images are  $A$  and  $D$ , then, trivially, agent 1 is a dictator. Equivalently, if they are  $F$  and  $C$ , then agent 2 is the dictator. Each of the remaining two cases forces  $F$  to be onto for two choices of  $j$ .

The domain overlap conditions remain. As not all domain points are admitted, this restriction defines a restriction set  $C_k$  for each agent. If  $F$  is not dictatorial, there are only two choices for the image set of  $F$ . Without loss of generality, assume it is  $\{A, B, C, E\}$ . We need to use the Nash and Pareto conditions to determine what sets are, and are not, in  $C_k$ . By the Pareto condition,  $\{B, E\} = \{(a_k, a^1 b, a^2 b), (b_k, b^1 a, b^2 a)\} \in C_k$ . Because of the Nash condition, regions  $\{C, D\} \in C_1$ . It is obvious why  $D \in C_1$ . To see why  $C = \{a_1, b^1 a, a^2 b\} \in C_1$ , note that the first voter using the strategy to get  $b$  results in  $a$ . If by changing strategy, the agent could get  $b$ , the original outcome wouldn't be a Nash equilibrium. Thus,  $C$  also is an admissible strategy. Similar arguments show that  $C_1$  contains all of the regions *except*  $(b^1, a^1 b, b^2 a)$  because this would change the outcome to  $b$ , which is a personally worse outcome. Likewise,  $C_2 = \{B, C, D, E, F\}$ . Based on the restrictions  $C_k$ , Corollary 3.2 holds. Consequently, either  $f$  is dictatorial, or (according to Corollary 3.1) two of the  $R_j$  classes of  $F$  are determined by one agent. Obviously, these two classes cannot be  $R_1$  and  $R_2$ , so one of them must be  $R_3$ . This returns us to the dictatorial situation because this agent determines the  $\{a, b\}$  outcome.

5. PROOFS -- Theorems 2 and 3

**Lemma 4.** Let  $I_j(k)$ ,  $j=1, 2, 3$ , satisfy the domain overlap condition. For each permutation  $(a, b, c)$  of  $(1, 2, 3)$ , each the sets in  $I^a(k) \cap I^b(k)$  meet at least one  $I^c(k)$  sets.



Proof. Suppose false. Without loss of generality, assume  $I^1(1,1) \cap I^2(1,1) \neq \emptyset$  for  $j = 1, 2$ . This means that  $I^1(1,1) \cap I^2(1,1)$  can't meet  $I^2(1,1)$  for  $j=1, 2$ . This contradicts the domain overlap assumption. ■

Proof of Theorem 2. The first part of the proof shows if  $F$  exists, there are two voters that can change  $R_j$  rankings for two different choices of  $j$ . Let  $L_j = \{k\}$  for  $s \neq k$ , there is an  $x_s$  in a  $I^j(s)$  class so that  $F(x_1, \dots, x_k, \dots, x_N)$  changes  $R_j$  classes as  $x_k$  changes  $I^j(k)$  classes. So, when only the  $k$ th voter changes classes, the  $R_j$  outcome changes.  $F$  is non-constant over at least two  $R_j$  sets, so, from the range overlap condition, for at least two choices of  $j$ ,  $L_j$  is nonempty.

Suppose  $|U_j| \geq 2$ , where, without loss of generality,  $1 \in L^1$  and  $2 \in L^2$ . For agent  $j$  to influence the  $R_j$  rankings, voters 3 to  $N$ , may need to be in specific  $I^j(k)$  classes,  $j=1, 2$ . According to Lemma 4, each voter can simultaneously satisfy both of the specified conditions. Hold these domain points fixed. For voter 1 to be in  $L^1$ ,  $x_2$  must be in a specific  $I^1(2)$  class, say  $I^1(2, u)$ . Likewise, for 2 to be in  $L^2$ ,  $x_1$  must be in  $I^2(1, v)$  for a specific choice of  $v$ . For  $k=1, 2$ , choose the  $I^3(k, \beta(k))$  class so that  $I^2(1, v) \cap I^3(1, \beta(1))$  meets both  $I^1(1)$  classes and  $I^1(2, u) \cap I^3(2, \beta(2))$  meets both  $I^2(2)$  classes. According to the domain overlap conditions, this is possible.

According to the construction, as  $x_k$  changes  $I^k$  classes, the image of  $F$  changes  $R_k$  classes,  $k=1, 2$ . Assume that  $R^k$  is the pair of images of  $F$  caused by this change of  $x_k$ ,  $k=1, 2$ . According to the construction, all outcomes in  $R^1 \cap R^2$  occur with appropriate choices of  $x_1$  and  $x_2$ . But, according to the range overlap condition, two sets in this intersection meet different  $R^3$  classes. This forces the  $R^3$  image to vary even though each  $x_k$  remains in a fixed  $I^3(k)$  class,  $k=1, \dots, N$ . This contradiction proves that each  $L_j$  has only one index, say 1.

To complete the proof, we need to show that for any choice of  $x_k$ ,  $k=2, \dots, N$ , the  $R_j$  image of  $F(x_1, \dots, x_N)$  depends only on which  $I^j(1)$  class contains  $x_1$ . If false, then there are  $\{x_k\}$ ,  $\{x_k\}$ ,  $k \geq 2$ , so that  $F(x_1, x_2, \dots, x_N)$  and  $F(x_1, x_2, \dots, x_N)$  are in different  $L_j$  classes. By holding  $x_1$  fixed and going through the various permutations interchanging  $x_k$  with  $x_k$ , the image of  $F$  must change  $R_j$  classes. This forces an index other than 1 to be in  $L_j$ . This contradiction completes the proof.

Next, we define  $g_i$ . Assume the images are  $R_j^i$ ,  $i=1, 2$ , and choose the indices on the range sets so that  $F(I^1(1, u)) = R_1^u$ ,  $u=1, 2$ , and that  $R_1^1 \cap R_2^1$  is

in  $R^3_1$  but not in  $R^3_2$ . Thus,  $R^1_1 \cap R^2_1 \cap R^3_2$  is empty. To define the  $I^2(1, v)$  image, note there is a choice of  $v$  so that  $I^1(1, 1) \cap I^2(1, v)$  meets both  $I^3(1)$  classes. Let  $v'$  be the other index. Then,  $F = g_1$  must map  $I^2(1, v')$  to  $R^2_1$ . If not, then  $F$  must map  $I^2(1, v)$  to  $R^2_1$ . Because  $I^1(1, 1) \cap I^2(1, v)$  meets both  $I^3(1)$  classes, it follows from the overlap conditions that  $R^1_1 \cap R^2_1$  meets both  $R^3$  classes. This contradiction proves the assertion. The determination of the  $I^3(1)$  image is done in the same fashion. This proof shows that the image of  $g_k$  cannot be constant valued over any  $R^j$ . Thus, each  $I^j(k)$  must have two disjoint elements. ■

(An alternative proof for everything after the first two paragraphs is to use the designated pairs of outcomes  $R^j$  to define an induced mapping into  $R^3$ . With an argument similar to Lemma 4, the range overlap conditions force  $F^j$  to miss two diametrical orthants. Proposition 1 applies immediately.)

**Lemma 5.** Assume that the three  $I^j(1)$  sets satisfy the restricted domain condition where, for each choice of  $j$ ,  $I^j(1)$  consists of two disjoint classes. For each set  $Z$  in  $I(1)$ , there is a permutation  $(a, b, c)$  of  $(1, 2, 3)$  so that  $Z$  is a singleton in  $I^a(1) \cap I^b(1)$ , but  $A$  is not a singleton in  $I^a(1) \cap I^c(1)$  or in  $I^b(1) \cap I^c(1)$ . Index  $c$  is called the "pivotal index" for  $Z$ .

**Example:** If  $Z = B = \{c_1 > c_3 > c_2\}$ , the pivotal index corresponds to the class  $P(1, 2)$ . As a quick way to determine the pivotal index, notice from Figure 1 that the two regions adjacent to this ranking region,  $B$ , all lie in one of the  $P(1, 2)$  classes, but this group  $\{A, B, C\}$  does not lie in only one  $P(i, j)$  class for any other choice of  $(i, j)$ .

The proof of the lemma is much the same as that of Lemma 4. Notice that for each choice of  $Z$ , there are two permutations, but both define the same pivotal index.

**Proof of Theorem 3.** Assume that the restrictions are imposed on voter 1, and let  $Z$  be one of the sets that is not in  $C_1$ . The first assertion is that, with a possible relabelling of the indices and with a possible change of choice of  $Z \notin C_1$ , we can assume that  $j = 1$  is the pivotal index for  $Z$  and that  $C^j_1 \cap I^j(1, s) \neq \emptyset$  for  $j = 2, 3, s = 1, 2$ . To see this, assume that 1 is the pivotal index for  $Z$ . Now, by definition,  $Z$  is not a singleton in  $I^1(1) \cap I^2(1)$  nor in  $I^1(1) \cap I^3(1)$ . If the other term in each intersection is in  $C_1$ , then, by use of the domain overlap conditions, it follows that the assertion is

satisfied. So, suppose either one, or both intersections have no terms in  $C_1$ . If both intersections fail to meet  $C_1$ , then  $C_1$  meets only one of the  $I^1(1)$  classes, so  $I^1(1)$  can be replaced with  $J^1(1)$  - the singleton equivalence class of everything. If one other class fails to have  $C_1$  meet both sets, then it too can be replaced with the singleton equivalence class. Here the overlap conditions are trivially satisfied, so this cannot occur. Thus,  $C_1$  meets both  $I^j(1, s)$ ,  $j = 2, 3$ ,  $s = 1, 2$  classes, and two of the sets in  $I^j(1)N^3(1)$  are not in  $C_1$ . This means that the assertion holds.

The remaining situation is that for one choice, say  $I^1(1)N^2(1)$ , the set accompanying  $Z$  is in  $C_1$ , but in  $I^1(1)N^3(1)$ , the set accompanying  $Z$ ,  $Y$ , is not in  $C_1$ . The pivotal index for  $Y$  is 2. We already know, from this construction, that the set accompanying  $Y$  in  $I^2(1)N^1(1)$  is not in  $C_1$ . If the set accompanying  $Y$  in  $I^2(1)N^3(1)$  is not in  $C_1$ , then we are in the same situation analyzed above for  $Z$ , so the assertion holds with  $Y$  and  $Z$  in place of  $Z$  and  $Y$ . If this set is in  $C_1$ , then we have elements of  $C_1$  in both  $I^1(1)$  and both  $I^2(1)$  classes. This completes the proof of the assertion.

Choose the indices on the  $I^j(1)$  classes so that before the restrictions are imposed,  $I^2(1, s)N^3(1, s)$  meets both  $I^1(1)$  classes. Likewise, choose the indices in the range so that  $R^2 \cap R^3$ ,  $s = 1, 2$ , meets both  $R^1$  classes. Choose the indices on  $I^j(1)$  so that, before the restrictions,  $a = I^1(1, 1)N^2(1, 1)N^3(1, 2) \neq \emptyset$  and  $\beta = I^1(1, 2)N^2(1, 2)N^3(1, 1) \neq \emptyset$ . Define  $F$  so that the  $R^j$  image of  $F$  is  $R^j$  iff  $x_1$  is in  $I^j(1, s)$ ,  $j = 2, 3$ ,  $s = 1, 2$ . Note that  $a$  is either  $\alpha$  or  $\beta$ . If both  $\alpha$  and  $\beta$  are in the restricted sets, then define the  $R^1$  image in any desired manner based on the entries in  $I^1$ . For instance, it can be determined by which  $I^1(2)$  class contains  $x_2$ , or by a majority vote of all voters, etc. If one of these sets, say  $\beta$ , is not in the restrictions, then let the  $R^1$  image of  $F$  be the unique  $R^1$  class that contains  $R^2 \cap R^3$  when  $x_1$  is in  $I^1(1, 2)$ . When  $x_1$  is in  $I^1(1, 1)$ , let the  $R^1$  image be determined in any desired manner.

To see that  $F$  is well defined over  $I^1N^2N^3$ , note that if  $x_1$  is not either  $\alpha$  or  $\beta$ , then it must be in  $I^2(1, s)N^3(1, s)$  for one choice of  $s$ . Thus, the image of  $F$  is  $R^2 \cap R^3$ , which meets both  $R^1$  classes. If  $x_1$  is  $\alpha$  or  $\beta$ , then the intersection of the  $R^2$  and  $R^3$  images uniquely defines the  $R^1$  image. This is the definition of  $F$ . Both values are not in the domain of  $x_1$ , so this completes the proof.

Next, suppose that  $I^1(1)$  consists of a single equivalence set, and  $I^2(1)$  and  $I^3(1)$  each have two sets.  $C_1$  has only two sets in  $I^2(1)N^3(1)$ , so choose the indices so that  $I^2(1, s)N^3(1, s) \neq \emptyset$  for  $s = 1, 2$ . The  $R^j$  image of  $F$

is  $R^s$  iff  $x_1 \in I^j(1, s)$ ,  $j = 2, 3$ ,  $s = 1, 2$ , and the  $R^1$  image is determined in any desired manner.

If the restrictions leave three sets in  $I^2(1)N^3(1)$ , then  $F$  always can be represented as a function of one variable. This is because, as I have already shown, if  $F$  is not represented by a function of one variable, then voter 1 must have an influence on the outcome of two classes. Clearly, this must be sets  $R^2$  and  $R^3$ . But, no matter how the  $R^j$  images of  $F$  are defined in terms of which  $I^j(1)$  class,  $j = 2, 3$ , contains  $x_1$ , there needs is one case where the image is not  $R^2 \cap R^3$ ,  $s = 1, 2$ . This forces a situation where the  $R^1$  image is uniquely determined, and it is determined by  $x_1$ . Because  $F: I^1 \rightarrow R^1$  and because  $I^1(1)$  is a singleton, it follows that the  $R^1$  image of  $F$  is fixed. ■

Proof of Corollary 3.2. This is a straightforward argument using the ideas motivating the statement. As in the proof of Theorem 3, we need to have two  $R^j$  sets where the third  $R^k$  outcome is not determined. This forces the definition of  $F$ . ■

References.

1. Arrow, K. J., (1963), *Social Choice and Individual Values*, 2nd. Edition. Cowles Foundation Monograph 12, Yale University Press, New Haven.
2. Chipman, J.S., and J.C. Moore, (1980), "Compensating Variation, consumer surplus, and welfare," *Amer. Econ Rev.*, **70**:933-949.
3. Cohen, J. E., (1986), "An uncertainty principle in demography and the unisex issue," *Amer. Statistician* **40**:32-39.
4. Donaldson, D., and J. A. Weymark, (1985), "Social choice in economic environments", Univ. of British Columbia Discussion paper 85-20.
5. Fishburn, P., (1970), "Arrow's impossibility theorem: Concise proof and infinite voters", *Jour. Econ. Theory*, **2**:103-106.
6. Gibbard, A., (1973), "Manipulation of voting schemes: A general result", *Econometrica*, **41**, 587-601.
7. Gibbard, A., A. Hylland, and J. A. Weymark, (1985) Arrow's theorem with a fixed feasible alternative", Univ. of British Columbia Discussion paper 85-15.
8. Good, I. J. and Y. Mittal, (1987), "The amalgamation and geometry of two-by-two contingency tables", *The Annals of Statistics*, **15**, 694-711.
9. Hansson, B. (1968), "Choice structure and preference relations", *Synthese* **18** 443-458.
10. Hansson, B., (1976), "The existence of group preferences," *Public choice*,

- 28:89-98.
11. Hurwicz, L., and D. Schmeidler, (1978), "Construction of outcome functions guaranteeing existence and pareto optimality of Nash equilibria", *Econometrica* 46: 1447-1474.
12. Kalai, E., E. Muller, and M. Satterthwaite, (1979), "Social welfare functions when preferences are convex, strictly monotonic, and continuous", *Public Choice* 34, 87-97.
13. Kalai, E., and E. Muller, (1977), "Characterization of domains admitting nondictatorial social welfare functions and nonmanipulable voting procedures", *Journal Econ. Theory*, 16:457-469.
14. Kalai, E., and Z. Ritz, (1980), "Characterization of private alternative domains admitting Arrow social welfare functions", *Journal Econ. Theory*, 22:23-26.
15. Kim, K. H., and F. W. Roush (1980), "Binary social welfare functions", *Journal of Economic Theory*, 23:267-277.
16. Nakamura, K., (1975), "The core of a simple game without ordinal preferences", *International Journal of Game Theory*, 4, 95-104.
17. Saari, D. G., (1978), "The geometry of departmental politics, of the scoring of track meets, and of Arrow's Social Choice Theorem" *Nu mimeo*.
18. Saari, D. G., (1988), "Symmetry, voting, and social choice", *The Mathematical Intelligence*, No. 3, 10:32-42.
19. Saari, D. G., (1987), "The source of some paradoxes from social choice and probability", *Journal of Econ. Theory* 41, 1 - 22.
20. Satterthwaite, M., (1975), "Strategy-proofness and Arrow's conditions: Existence and correspondence theorem for voting procedures and social welfare functions." *Journal of Economic Theory* 10:187-217.
21. Sen A. K., (1986), "Social choice theory", Chp 22, p 1073-1182, in *Handbook of Mathematical Economics*, ed. K. Arrow, M. Intriligator, North-Holland, Amsterdam.
22. Sen A. K., (1970), "The impossibility of a Paretian liberal", *Journal of Political Economy* 72:152-157.
23. Steinhaus, H., and S. Trybula, (1959), "On a paradox in applied probability", *Bull. Acad. Polo Scie.*, 7:67-69.
24. Varian, H., (1984), *Microeconomic Analysis*, 2nd Edition, Norton, New York.
25. Wilson, R., (1972), "Social Choice theory without the Pareto principle", *Journal Econ Theory* 5:478-486.

Figure 1

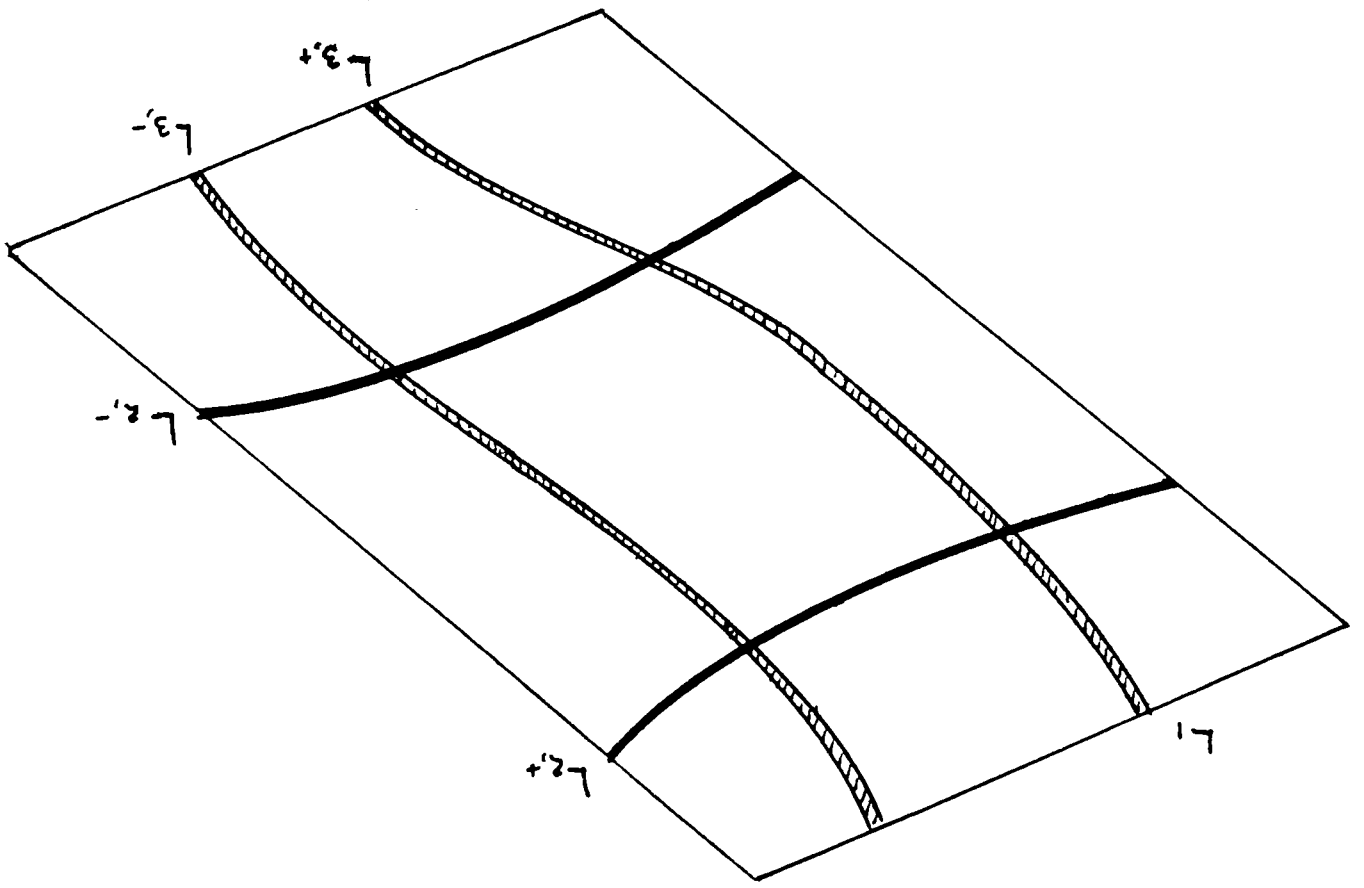

Figure 2

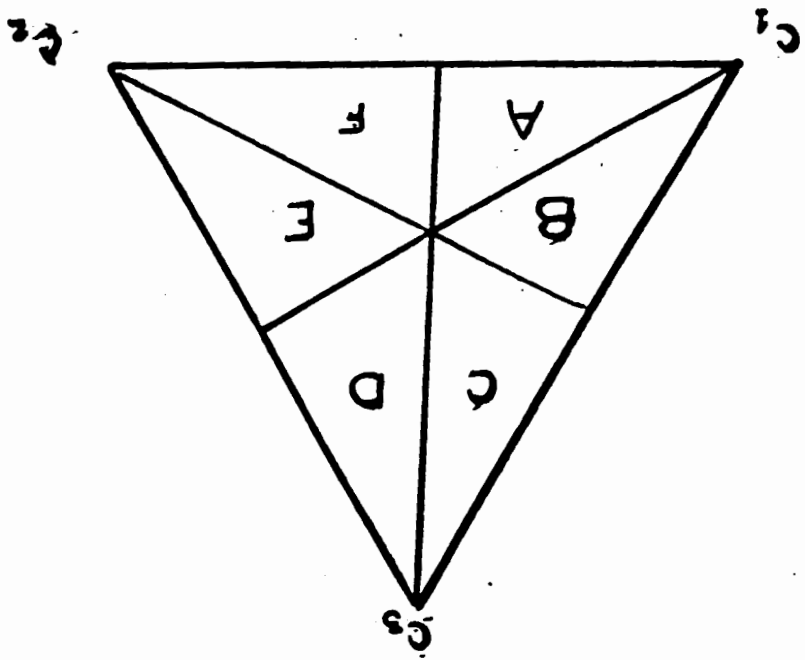

Fig. 3

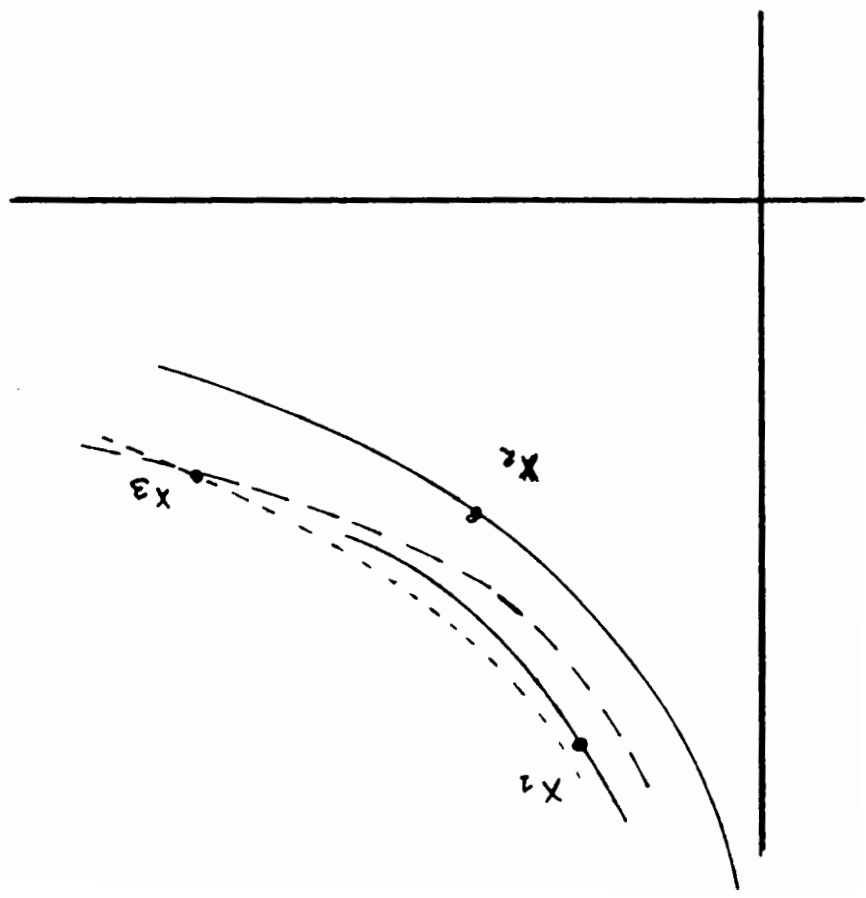



Figure 4

